

THRU-FASTENED PANEL



MAX-RIB



MEGA-RIB



MULTI-RIB



MULTI-V

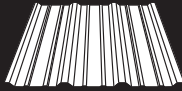

R-PANEL



MINI-RIB



5V CRIMP

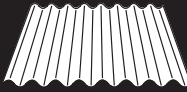

M-COR

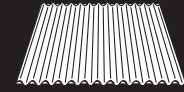

MULTI-COR



U-PANEL

HANDLING & INSTALLATION INFORMATION



HANDLING & INSTALLATION



INSTALLATION INFORMATION

Handling and Fastening Specifications

The information shown are suggestions or guidelines and are not intended to cover all applications or building requirements. It is the responsibility of the designer/installer to ensure that this information meets particular building conditions and/or code requirements. It is also the responsibility of the installer to ensure that all OSHA and/or safety requirements are understood and met. McElroy Metal shall not be liable for any claim or claims which arise out of the handling or installation of the material.

GENERAL HANDLING

When handling metal panels, care should be taken to protect the finish from scratching or abrasion. Dragging panels across one another will unnecessarily increase the risk of scratching. Individual panels should be carried vertical to the ground by grasping the edge of the panel.

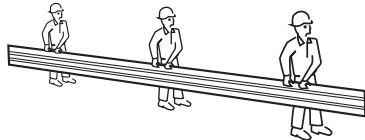

MECHANICAL HANDLING

A forklift or crane can be used to handle unopened bundles up to 25' in length. For forklift unloading, forks should be spread to maximum width and placed at center line weight distribution of bundle. For crane unloading, a spreader bar should be used to evenly distribute the weight of the bundle. Cable supports will cause damage to the panels and should not be used.

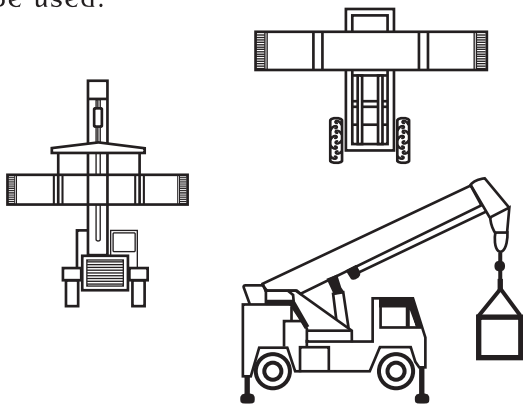

STORAGE AND PROTECTION

Bundled material should be kept dry and above ground. Material should be tarped (not with plastic) or protected from weather conditions by other means. Allow for proper air circulation to prevent moisture buildup under tarp. Elevate one end of the bundles to allow for moisture runoff. If the panels become wet, all panels should be removed from bundles and individually dried.

Prolonged storage of panels is not recommended. If conditions do not permit immediate installation, extra care should be taken to protect sheets from developing white/red rust or watermarks.

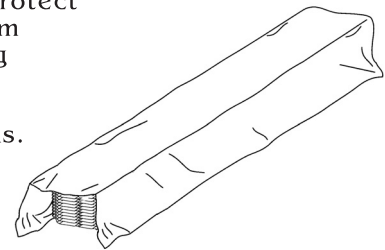

PANEL INSPECTION

All bundles of panels should be inspected upon delivery from McElroy Metal. Any damage or moisture present on panels should be reported to carrier and noted on bill of lading. In addition, McElroy Metal must be notified of damage or moisture within **48 hours** of discovery.

FIELD CUTTING

Some field cutting and fitting of panels is to be expected by the installer and minor field corrections are a part of normal installation work. Always cut one panel at a time. For small cuts, hand-held shears or electric nibblers are recommended. For best cutting results a panel shear is recommended. Shears and nibblers are available through McElroy Metal. Cutting of panels and driving of fasteners will create metal shavings. These metal shavings must be swept or removed from the panel surface. Failure to do so will cause rust stains on the panel surface and will void any warranty.

FASTENER POSITIONS LAPPING INFORMATION



MAX-RIB

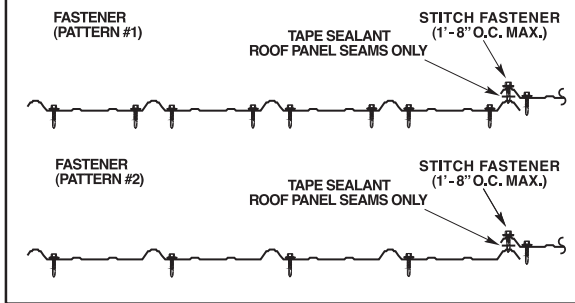

R-PANEL

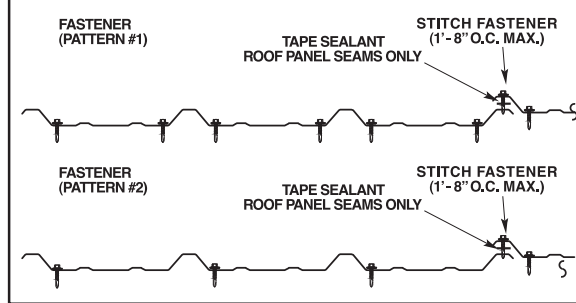

MINI-RIB

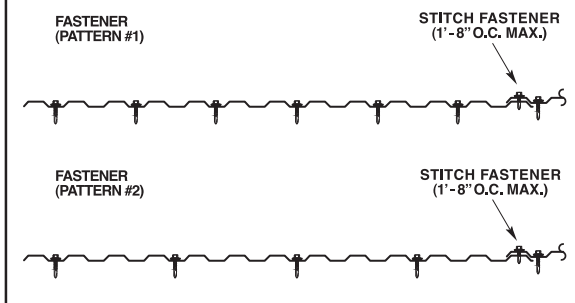

MEGA-RIB

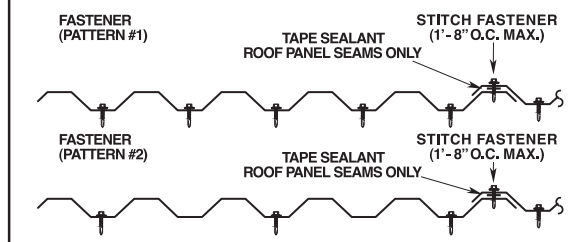

MULTI-V



5V CRIMP

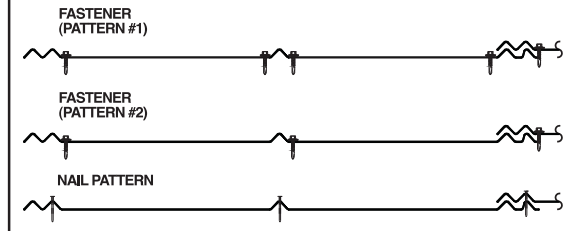

MULTI-RIB

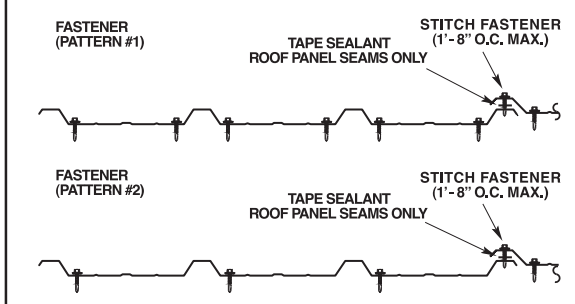

MULTI-COR

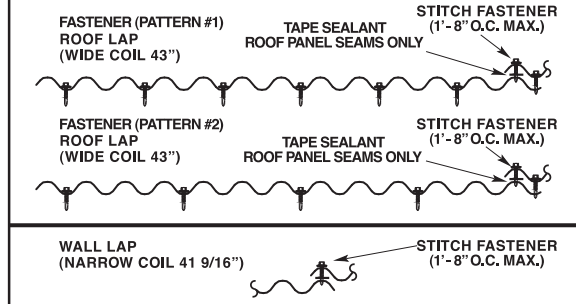

U-PANEL

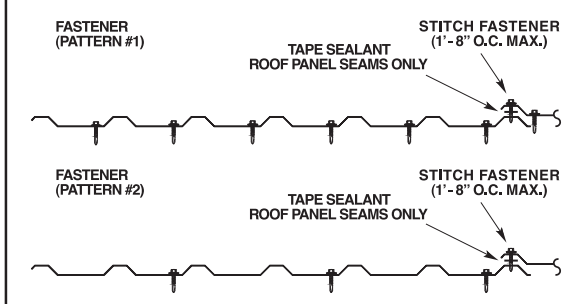

M-COR

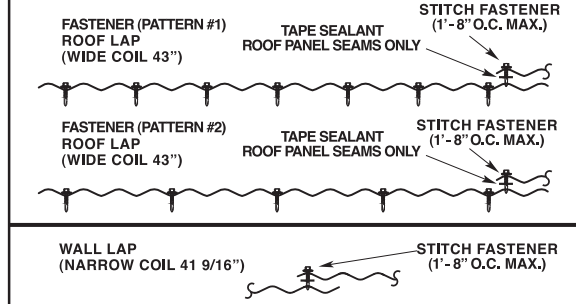

NOTE: FASTENER PATTERN #1 (EAVES, END LAPS AND RIDGE) - FASTENER PATTERN #2 (ALL OTHER LOCATIONS)

INST/PRODUCT INFORMATION



FASTENING DETAILS

The use of proper fasteners and installation procedures is an important factor in the appearance and performance of the panel system. Roofing and siding may be installed using fasteners with weather seal washers.

METAL FASTENERS

CORRECT	TOO LOOSE	TOO TIGHT
Sealing material slightly visible at edge of metal washer. Assembly is weathertight.	Sealing material not visible. Not enough compression to seal properly.	Sealing material extruded beyond edge of washer.

NAILS

CORRECT	TOO LOOSE	TOO TIGHT
Sealing material slightly visible at edge of nail head. Assembly is weathertight.	Sealing material not visible. Not enough compression to seal properly.	Sealing material extruded beyond edge of washer.

McElroy Metal shall not be liable for any claim or claims which arise out of the handling or installation of the material.

MANUFACTURING LOCATIONS

- | | | | | |
|---------------------------|----------------------|-------------------------|-----------------------|--------------------|
| ADELANTO, CA | ASHBURN, GA | BOSSIER CITY, LA | CLINTON, IL | DIAMOND, MO |
| HOUSTON, TX | LEWISPORT, KY | MARSHALL, MI | MAUSTON, WI | MERKEL, TX |
| PEACHTREE CITY, GA | | SUNNYVALE, TX | WINCHESTER, VA | |

McELROY METAL **SERVICE** CENTER

- | | | | |
|---|--|---|---|
| 17031 Koala Road
Adelanto, CA 92301 | 5215 Leo St.
Alexandria, LA 71301 | 1007 Wilso Dr.
Baltimore, MD 21223 | 1500 Hamilton Rd.
Bossier City, LA 71111 |
| 3052 Yadkin
Chesapeake, VA 23323 | 9476 Meadowbrook Rd.
Clinton, IL 61727 | 3215 Highway 59
Diamond, MO 64840 | 390 N. Valley Dell Dr.
Fenton, MO 63026 |
| 409 Lovejoy Road
Ft. Walton Beach, FL 32548 | 3014 Lincoln Court
Garland, TX 75041 | 1440 Aldine Bender Road
Houston, TX 77032 | 10504 E. 59th Street
Indianapolis, IN 46236 |
| 9435 U,S, Hwy. 60 W.
Lewisport, KY 42351 | 1020 Veterans St.
Mauston, WI 53948 | 5123 Terminal Dr.
McFarland, WI 53558 | 514 Cave Road
Nashville, TN 37210 |
| 8304 Hwy. 70 E.
North Little Rock, AR 72117 | 613 North Bierdeman Rd.
Pearl, MS 39208 | 8511 Industrial Drive
Pearland, TX 77584 | 7450 Tower Street
Richland Hills, TX 76118 |
| 8200 Berry Ave., Suite 100
Sacramento, CA 95826 | 1365 Dean Forest Rd.
Savannah, GA 31405 | 7355 Oakley Industrial Blvd.
Union City, GA 30291 | |
| | 1144 Silstar Rd.
West Columbia, SC 29170 | 325 McGhee Rd.
Winchester, VA 22603 | |



CORPORATE OFFICE
1500 HAMILTON RD. · BOSSIER CITY, LA 71111

Website: www.mcelroymetal.com · E-mail: info@mcelroymetal.com