



*50 Years and Growing  
Family Owned - Quality Focused*

# STANDARD TRIM DETAILS

MT TRIM FOR HOUSTON PANEL PROFILES

VOLUME: IX  
REVISED: 04-25-16

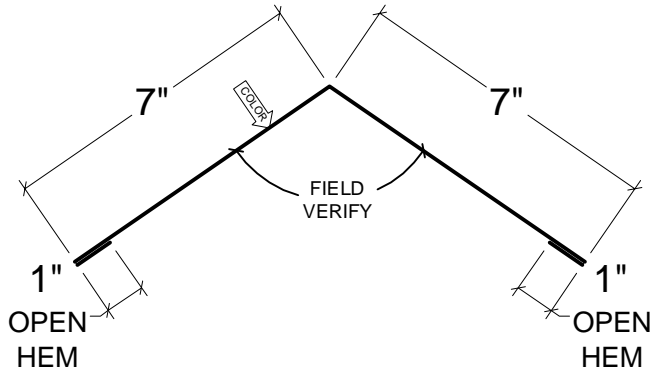

STRETCH OUT: 16"

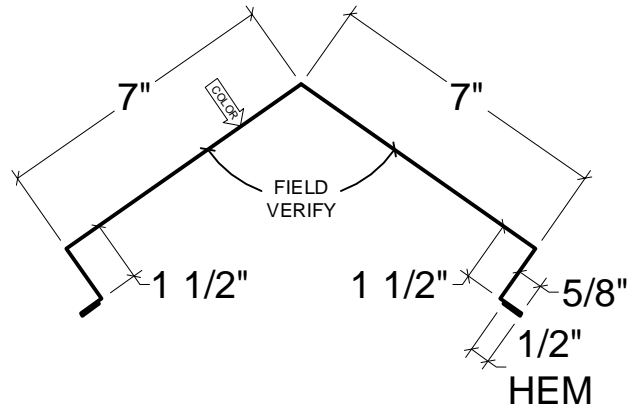

STRETCH OUT: 19 1/4"

MT-2 REVISION: 1 DATE: 5/17/13  
DESCRIPTION: RIDGE CAP

MT-3 REVISION: 2 DATE: 6/18/13  
DESCRIPTION: VENTED RIDGE CAP

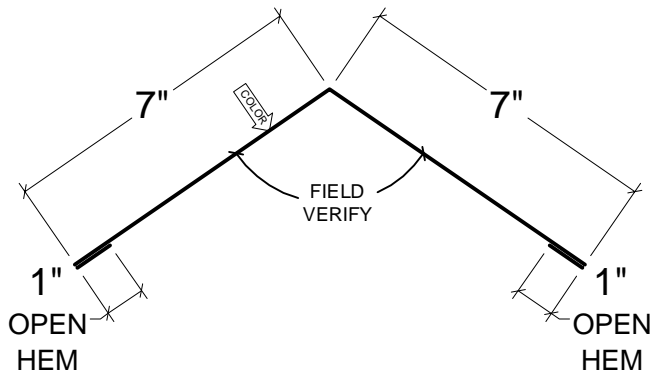

STRETCH OUT: 16"

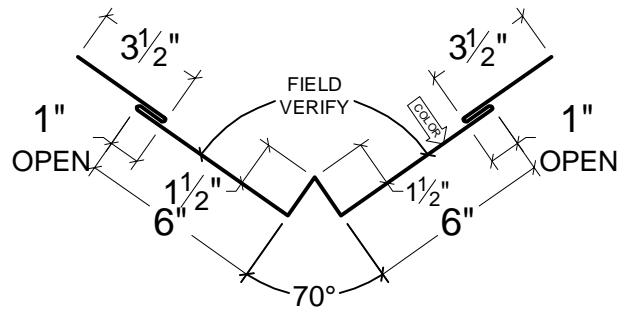

STRETCH OUT: 24"

MT-5 REVISION: 1 DATE: 5/17/13  
DESCRIPTION: HIP CAP

MT-7 REVISION: 1 DATE: 7/14/09  
DESCRIPTION: VALLEY TRIM w/ INTEGRAL CLIP

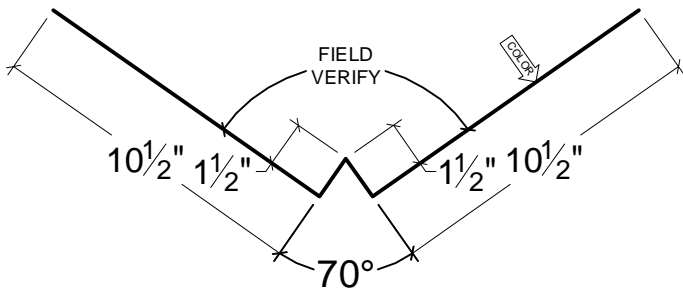

STRETCH OUT: 24"

MT-8 REVISION: 1 DATE: 7/14/09  
DESCRIPTION: VALLEY w/ OUT CLEAT



DETAIL TYPE: STANDARD TRIM

PANEL TYPE: VARIES

REVISION	DATE:
10	12/29/16
11	01/19/16

PAGE NUMBER: 1

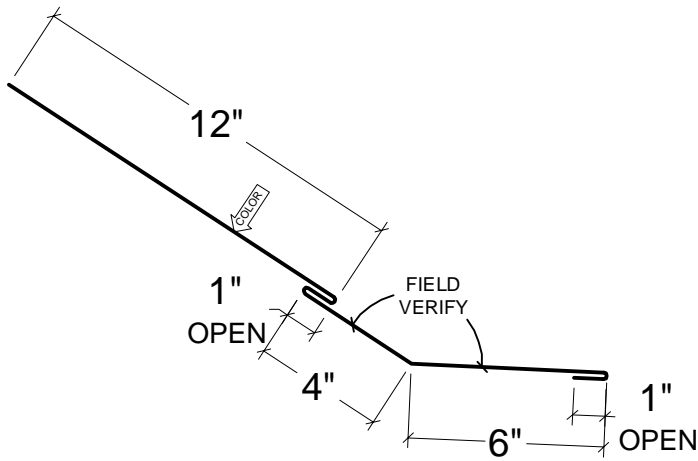

STRETCH OUT: 24"

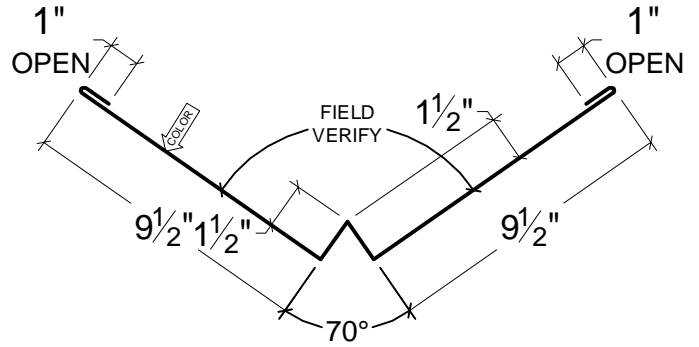

USE WITH (2) MT-11 VALLEY CLIP

STRETCH OUT: 24"

MT-9

REVISION: 1 DATE: 7/14/09  
DESCRIPTION: TRANSITION TRIM w/ INTEGRAL CLEAT

MT-10

REVISION: 1 DATE: 7/14/09  
DESCRIPTION: VALLEY TRIM

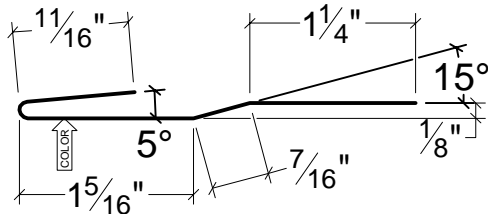

HOUSTON PLANT ONLY

NOTE!  
MEMBER IS ROLL FORMED AND  
THE DIMENSIONS ARE FINAL  
USE WITH MT-10 VALLEY TRIM

STRETCH OUT: 3 5/8"

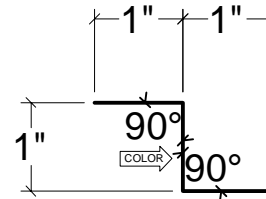

STRETCH OUT: 3"

MT-11

REVISION: 3 DATE: 04-25-16  
DESCRIPTION: VALLEY CLIP

MT-13

REVISION: 2 DATE: 7/21/11  
DESCRIPTION: 1" ZEE CLOSURE (USE w/ INSTALOK, SL-LO, SL CURVE, FLUSH & WAV

NOTE!  
TOP PERFORATION WILL  
BE PRESSED

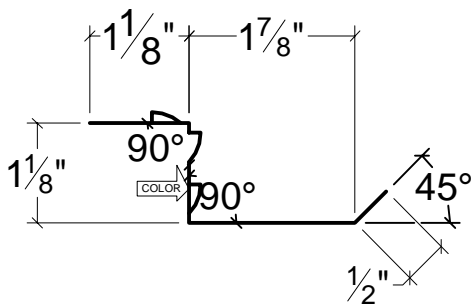

DO NOT USE ON  
WEATHER-TIGHT  
WARRANTY PROJECTS

PERFORATIONS DIFFERENT AT HOUSTON PLANT

STRETCH OUT: 4 5/8"

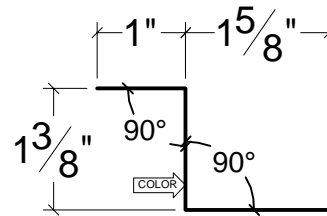

STRETCH OUT: 4"

MT-13P

REVISION: 4 DATE: 06-22-12  
DESCRIPTION: 1 1/8" PERFORATED ZEE CLOSURE(USE w/ INSTALOK, SL-LO, SL CURVE & FLUSH PINS)

MT-14

REVISION: 1 DATE: 09/11/15  
DESCRIPTION: 138T ZEE CLOSURE



DETAIL TYPE:

STANDARD TRIM

REVISION

DATE:

11

01/19/16

12

04/25/16

PANEL TYPE:

VARIES

PAGE NUMBER:

2

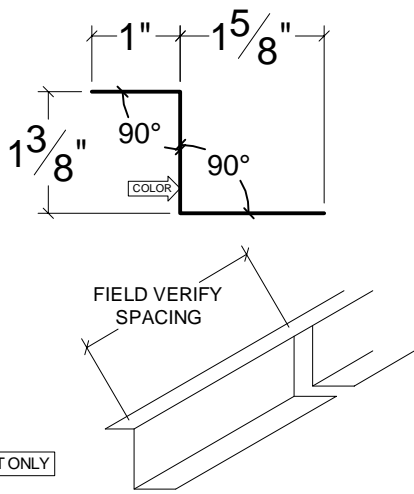

HOUSTON PLANT ONLY

STRETCH OUT: 4"

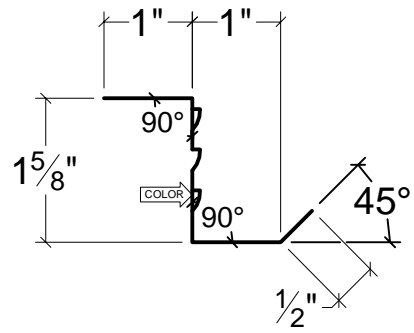

DO NOT USE ON WEATHER-TIGHT WARRANTY PROJECTS

PERFORATIONS DIFFERENT AT HOUSTON PLANT

STRETCH OUT: 4 1/8"

MT-14N

REVISION: 6

DATE: 09/11/15

DESCRIPTION: 138T NOTCHED ZEE CLOSURE 12 & 16"

MT-14P

REVISION: 2

DATE: 7/21/11

DESCRIPTION: 1 5/8" PERFORATED ZEE CLOSURE (USE w/ SL-HI PANEL)

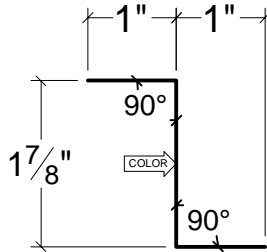

STRETCH OUT: 3 7/8"

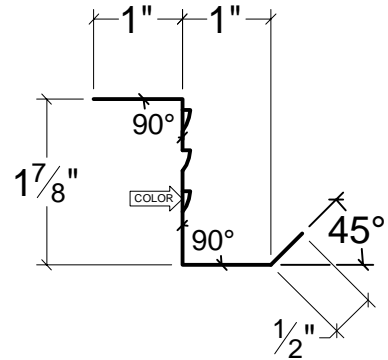

DO NOT USE ON WEATHER-TIGHT WARRANTY PROJECTS

PERFORATIONS DIFFERENT AT HOUSTON PLANT

STRETCH OUT: 4 3/8"

MT-15

REVISION: 2

DATE: 7/21/11

DESCRIPTION: 1 7/8" ZEE CLOSURE (USE w/ PERMASEAM PANEL)

MT-15P

REVISION: 2

DATE: 7/21/11

DESCRIPTION: 1 7/8" PERFORATED ZEE CLOSURE (USE w/ PERMASEAM PANEL)

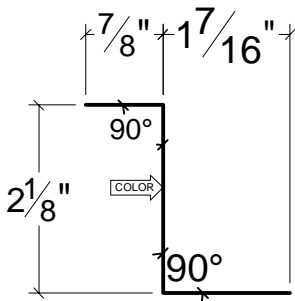

STRETCH OUT: 4 7/16"

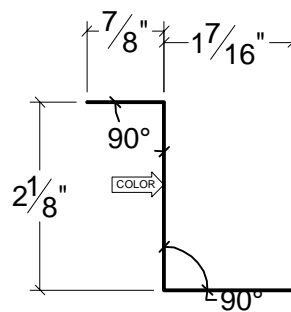

FIELD VERIFY WIDTH

HOUSTON PLANT ONLY

WIDTH: 16", 18", 24"

STRETCH OUT: 4 7/16"

MT-16

REVISION: 2

DATE: 06/22/12

DESCRIPTION: 2 1/8" ZEE CLOSURE (USE w/ JSM 200 & SL BATTEN PANEL)

MT-16WT

REVISION: 2

DATE: 06/22/12

DESCRIPTION: 2" ZEE CLOSURE WITH TABS



DETAIL TYPE:

STANDARD TRIM

REVISION

DATE:

10

12/29/16

11

01/19/16

PANEL TYPE:

VARIES

PAGE NUMBER:

3

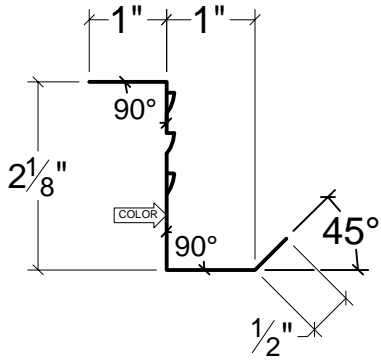

PERFORATIONS DIFFERENT AT HOUSTON PLANT

DO NOT USE ON WEATHER-TIGHT WARRANTY PROJECTS

STRETCH OUT: 4 5/8"

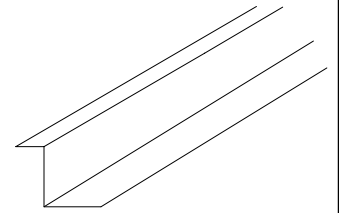
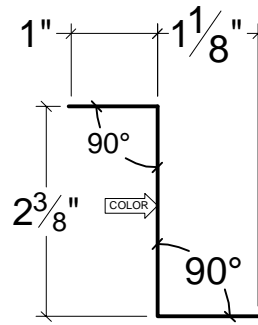

STRETCH OUT: 4 7/16"

MT-16P	REVISION: 1	DATE: 7/14/09	MT-17	REVISION: 0	DATE: 03/11/13
	DESCRIPTION: 2 1/8" PERFORATED ZEE CLOSURE (USE w/ JSM 200 & SL BATTEN PANEL)			DESCRIPTION: 238T ZEE CLOSURE	

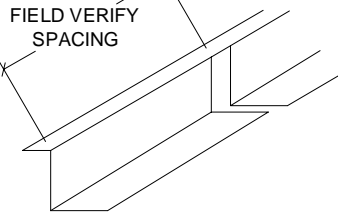
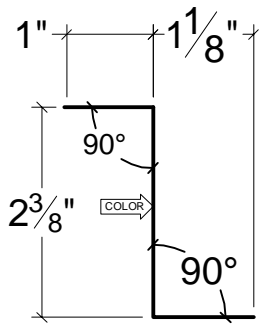

HOUSTON PLANT ONLY

WIDTH: 16", 18", 24"

STRETCH OUT: 4 7/16"

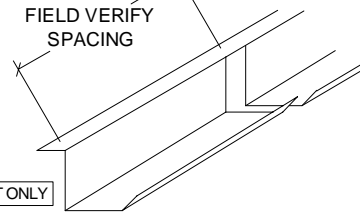
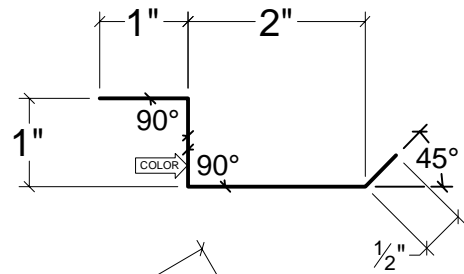

HOUSTON PLANT ONLY

STRETCH OUT: 4 1/2"

MT-17-N	REVISION: 5	DATE: 10/30/12	MT-19	REVISION: 1	DATE: 7/14/09
	DESCRIPTION: 238T NOTCHED ZEE CLOSURE			DESCRIPTION: 1" E-Z-Z (USE w/ INSTALOK, SL-LO, SL CURVE & FLUSH PANELS)	

NOTE! TOP PERFORATION WILL BE PRESSED

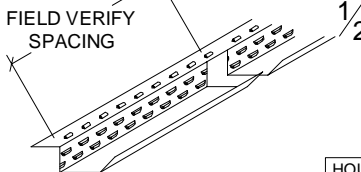
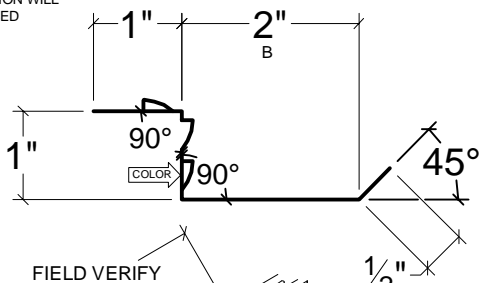

HOUSTON PLANT ONLY

DO NOT USE ON WEATHER-TIGHT WARRANTY PROJECTS

STRETCH OUT: 4 1/2"

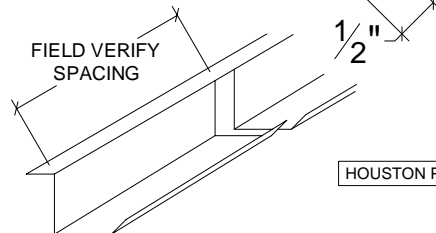
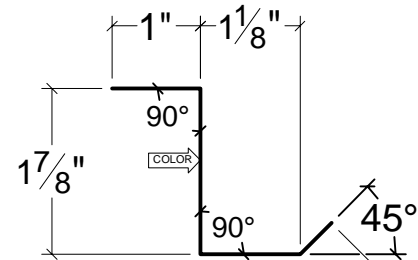

HOUSTON PLANT ONLY

STRETCH OUT: 4 1/2"

MT-19P	REVISION: 2	DATE: 10/26/11	MT-21	REVISION: 1	DATE: 7/14/09
	DESCRIPTION: 1" PERFORATED E-Z-Z (USE w/ INSTALOK, SL-LO, SL CURVE & FLUSH PANELS)			DESCRIPTION: 1 7/8" E-Z-Z (USE w/ PERMASEAM PANEL)	



DETAIL TYPE:

STANDARD TRIM

REVISION

DATE:

10

12/29/16

11

01/19/16

PANEL TYPE:

VARIES

PAGE NUMBER:

4

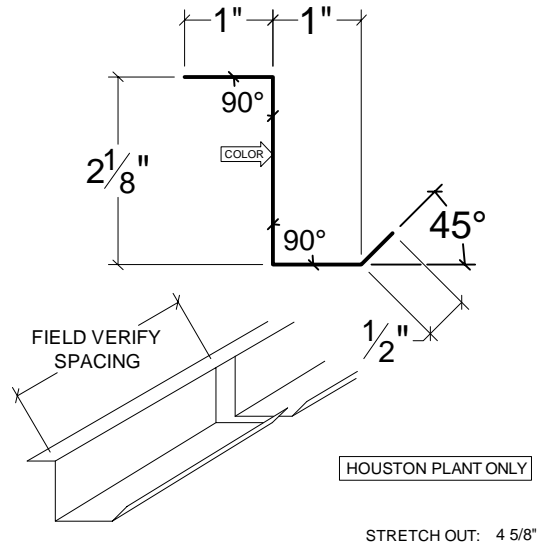
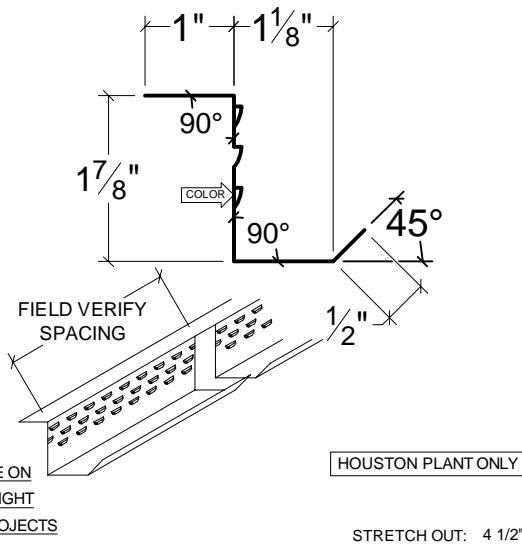

MT-21P REVISION: 1 DATE: 7/14/09  
 DESCRIPTION: 1 7/8" PERFORATED E-Z-Z (USE w/ PERMASEAM PANEL)

MT-22 REVISION: 1 DATE: 7/14/09  
 DESCRIPTION: 2 1/8" E-Z-Z (USE w/ JSM 200 & SL BATTEN PANEL)

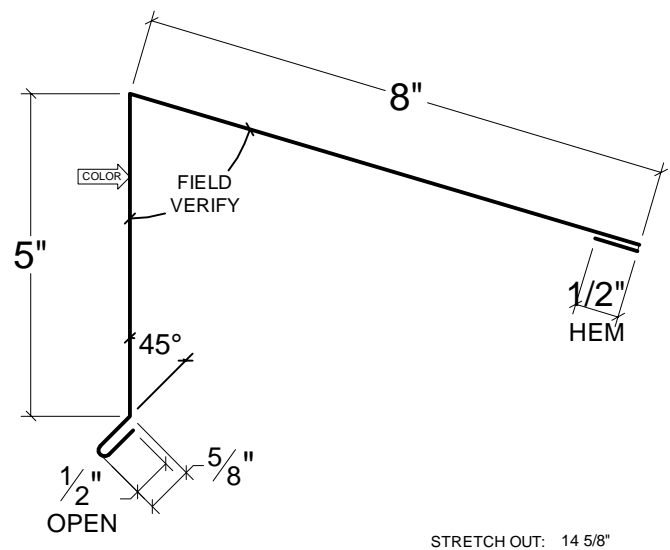
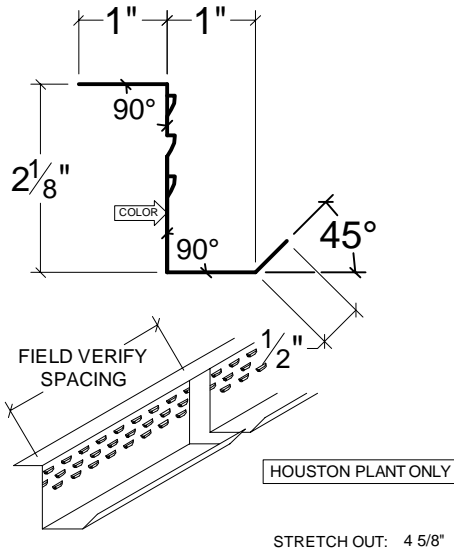

MT-22P REVISION: 1 DATE: 7/14/09  
 DESCRIPTION: 2 1/8" PERFORATED E-Z-Z (USE w/ JSM 200 & SL BATTEN PANEL)

MT-25 REVISION: 4 DATE: 3/12/13  
 DESCRIPTION: HIGH EAVE TRIM (COMMERCIAL/INDUSTRIAL)

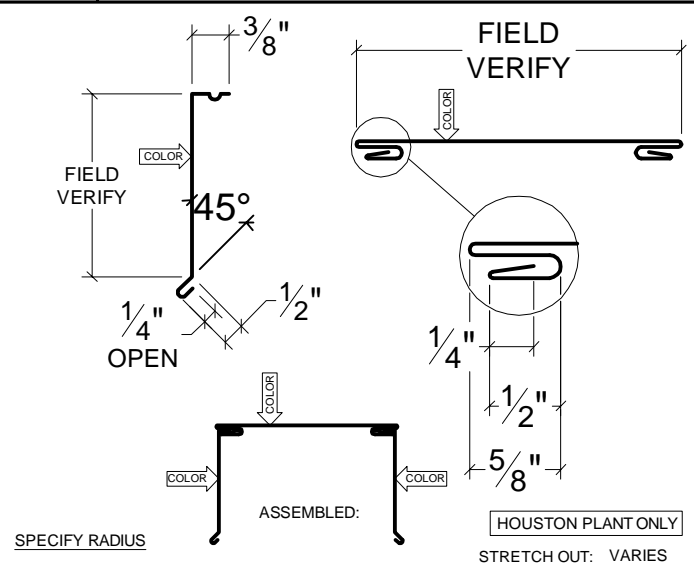
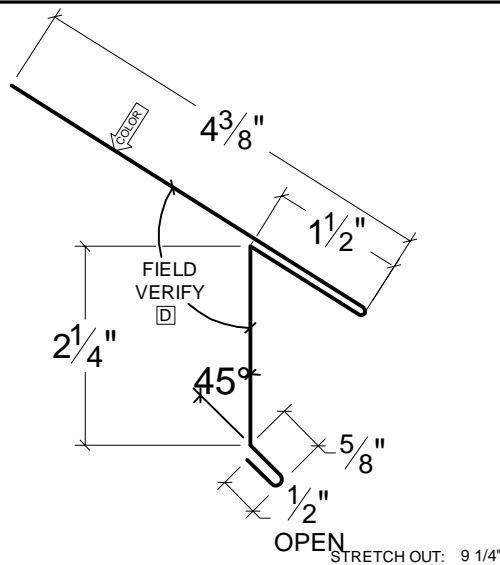

MT-26 REVISION: 3 DATE: 9/06/11  
 DESCRIPTION: STANDARD EAVE TRIM

MT-27 REVISION: 1 DATE: 7/14/09  
 DESCRIPTION: CURVED COPING (3 PC. SYSTEM)



DETAIL TYPE:	STANDARD TRIM	
PANEL TYPE:	VARIES	
REVISION	10	DATE: 12/29/16
REVISION	11	DATE: 01/19/16
PAGE NUMBER:	5	

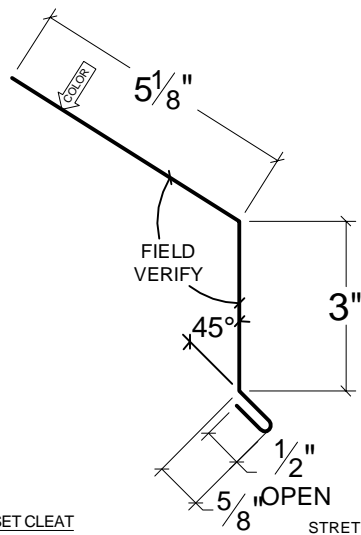

USE WITH MT-38 OFFSET CLEAT

STRETCH OUT: 9 1/4"

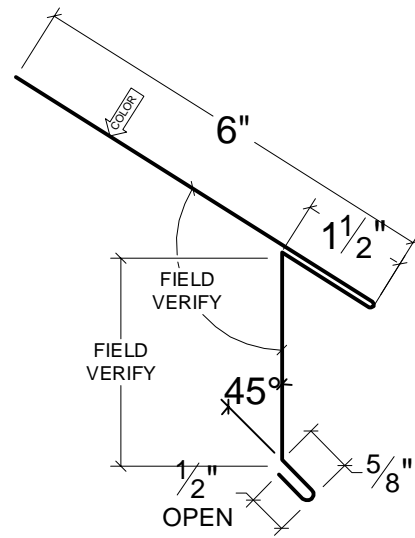

STRETCH OUT: VARIES

MT-28

REVISION: 4

DATE: 9/06/11

DESCRIPTION: ALTERNATE EAVE TRIM

MT-29

REVISION: 3

DATE: 12/21/09

DESCRIPTION: ALTERNATE EAVE TRIM

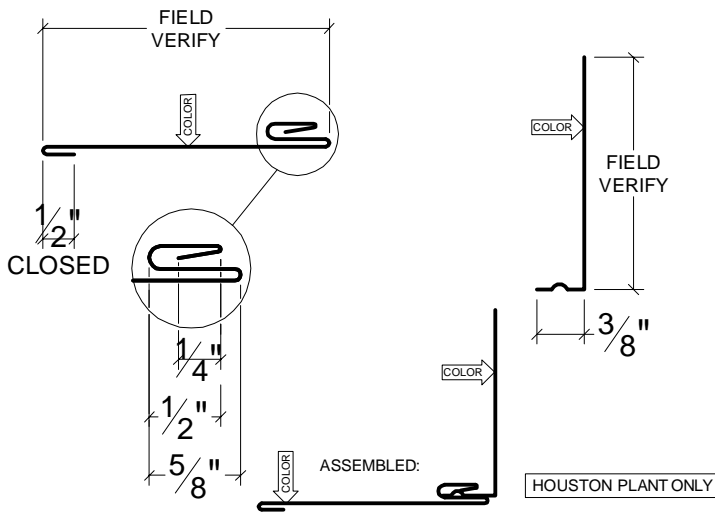

SPECIFY RADIUS

STRETCH OUT: VARIES

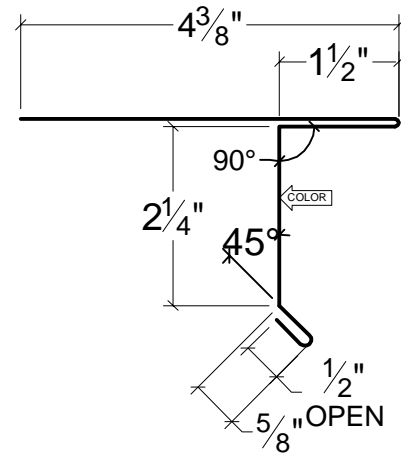

STRETCH OUT: 9 1/4"

MT-30

REVISION: 1

DATE: 7/14/09

DESCRIPTION: CURVED SIDEWALL (2 PC. SYSTEM)

MT-31

REVISION: 4

DATE: 9/06/11

DESCRIPTION: STANDARD RAKE TRIM

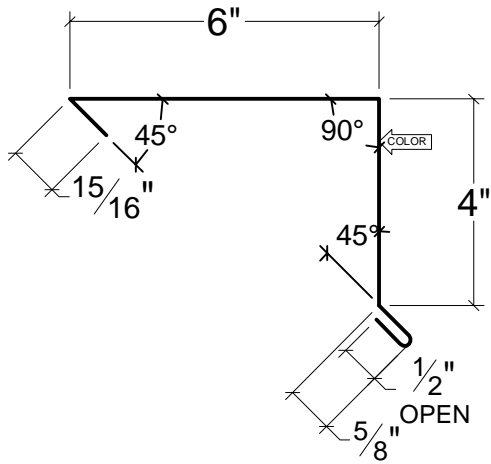

STRETCH OUT: 12 1/16"

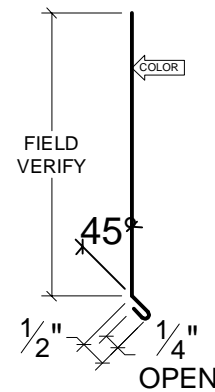

STRETCH OUT: VARIES

MT-32

REVISION: 5

DATE: 10/26/11

DESCRIPTION: ALTERNATE RAKE TRIM

MT-33

REVISION: 3

DATE: 12/21/09

DESCRIPTION: CURVED FASCIA TRIM (FOR CURVED SNAP LOCK)



DETAIL TYPE:

STANDARD TRIM

REVISION

DATE:

10

12/29/16

11

01/19/16

PANEL TYPE:

VARIES

PAGE NUMBER:

6

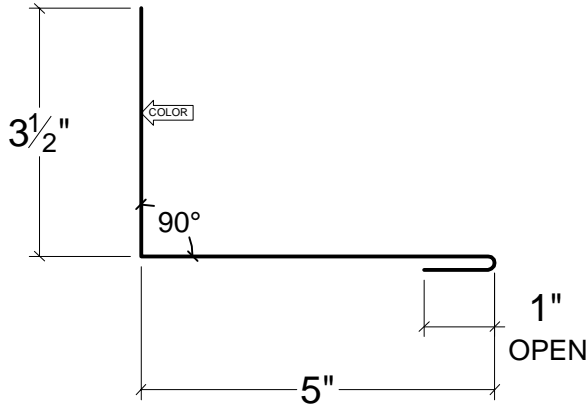

STRETCH OUT: 9 1/2"

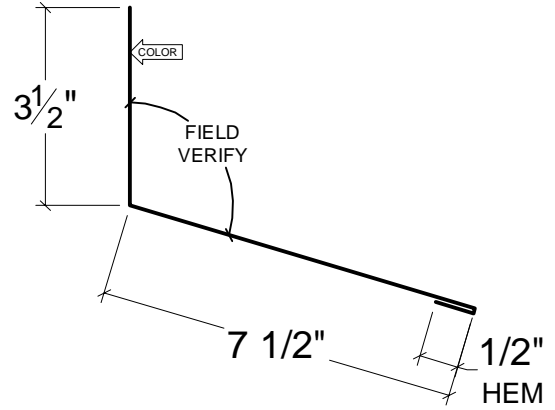

SPECIFY RADIUS:

STRETCH OUT: 11 1/2"

MT-34

REVISION: 1

DATE: 7/14/09

DESCRIPTION: STANDARD SIDEWALL TRIM

MT-35

REVISION: 2

DATE: 10/1/15

DESCRIPTION: STANDARD HEADWALL TRIM

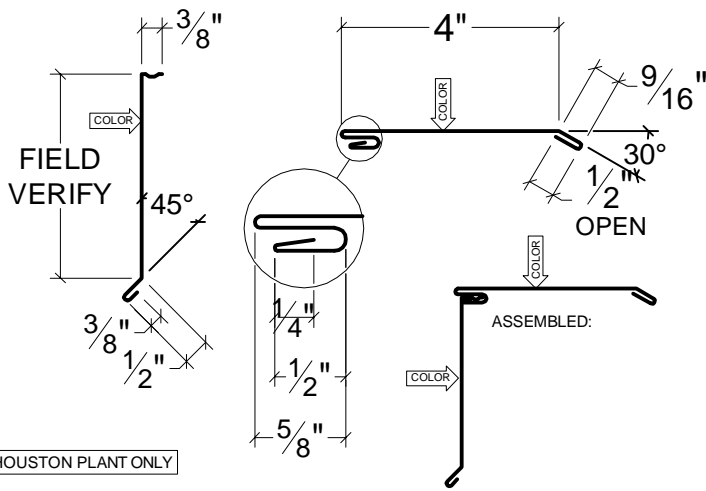

SPECIFY RADIUS:

STRETCH OUT: VARIES

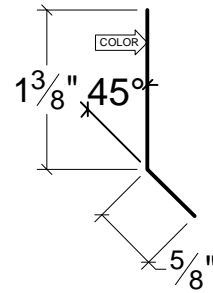

ANY COLOR

STRETCH OUT: 2"

MT-36

REVISION: 1

DATE: 7/14/09

DESCRIPTION: CURVED RAKE TRIM (2PC. SYSTEM)

MT-37

REVISION: 1

DATE: 7/14/09

DESCRIPTION: STANDARD CLEAT

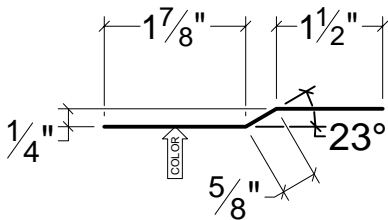

STRETCH OUT: 4"

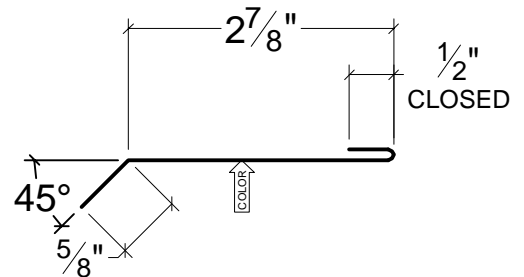

STRETCH OUT: 4"

MT-38

REVISION: 1

DATE: 7/14/09

DESCRIPTION: STANDARD OFFSET CLEAT

MT-39

REVISION: 1

DATE: 7/14/09

DESCRIPTION: FASCIA/OFFSET CLEAT



DETAIL TYPE:

STANDARD TRIM

REVISION

DATE:

10

12/29/16

11

01/19/16

PANEL TYPE:

VARIES

PAGE NUMBER:

7



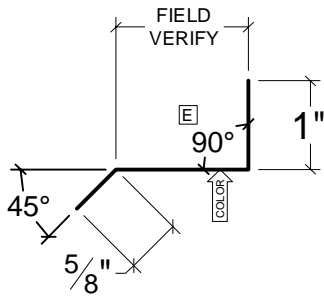

STRETCH OUT: VARIES

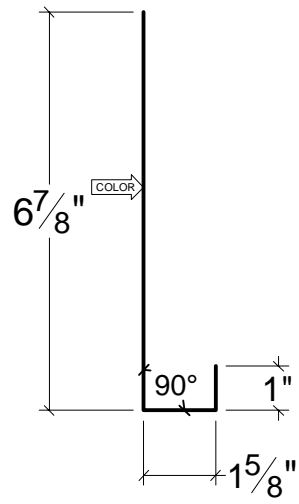

STRETCH OUT: 9 1/2"

MT-40

REVISION: 1 DATE: 7/14/09  
DESCRIPTION: FASCIA CLEAT

MT-42

REVISION: 2 DATE: 10/26/11  
DESCRIPTION: FASCIA TRIM

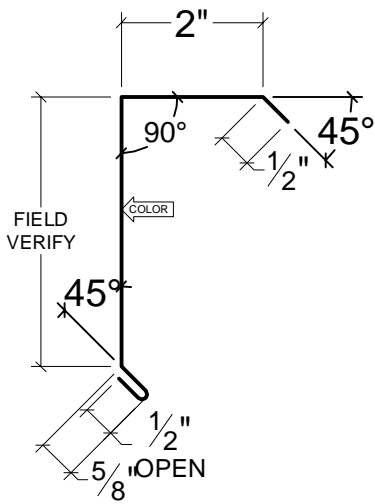

STRETCH OUT: VARIES

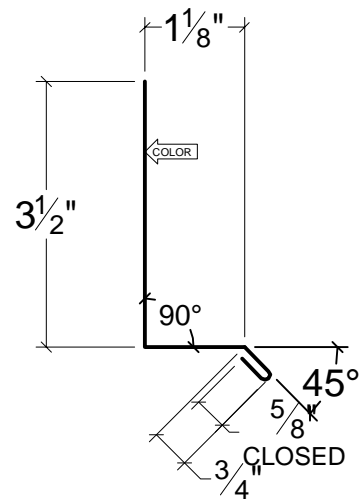

STRETCH OUT: 6"

MT-43

REVISION: 3 DATE: 12/21/09  
DESCRIPTION: FASCIA TRIM

MT-44

REVISION: 2 DATE: 3/07/13  
DESCRIPTION: 1 1/8" SILL TRIM

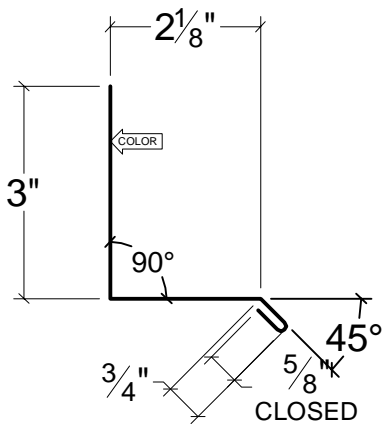

STRETCH OUT: 6 1/2"

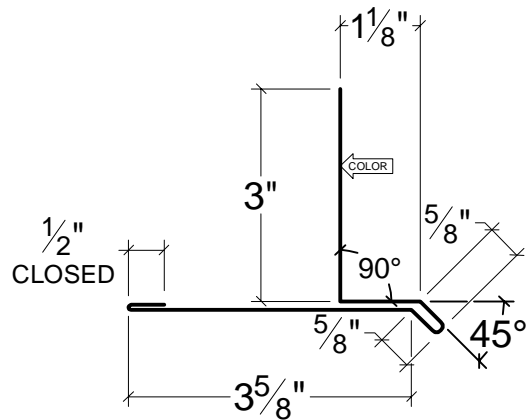

STRETCH OUT: 9 1/2"

MT-45

REVISION: 1 DATE: 7/14/09  
DESCRIPTION: 2" SILL TRIM

MT-46

REVISION: 2 DATE: 7/14/09  
DESCRIPTION: 1" SILL w/ SOFFIT



DETAIL TYPE:

STANDARD TRIM

REVISION

DATE:

10

12/29/16

11

01/19/16

PANEL TYPE:

VARIES

PAGE NUMBER:

8

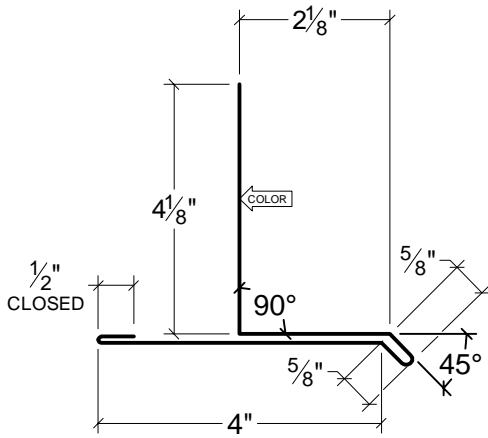

STRETCH OUT: 12"

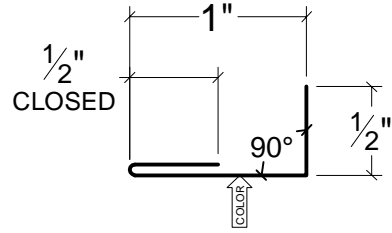

STRETCH OUT: 2"

MT-47

REVISION: 1      DATE: 7/14/09  
DESCRIPTION: 2" SILL w/ SOFFIT

MT-48

REVISION: 1      DATE: 7/14/09  
DESCRIPTION: SOFFIT TRIM

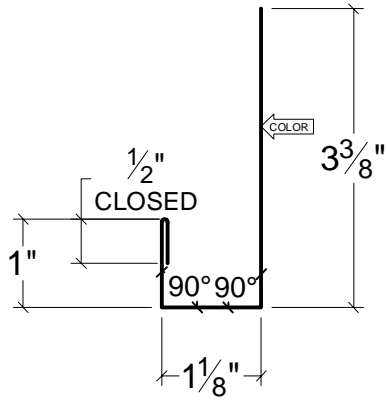

STRETCH OUT: 6"

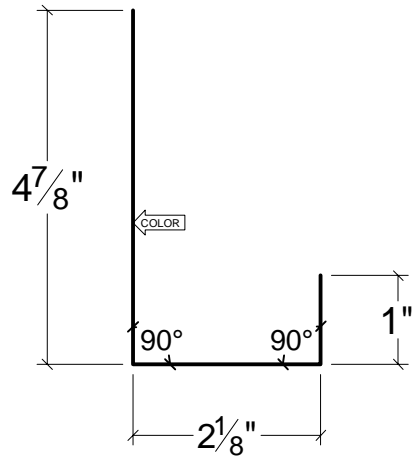

STRETCH OUT: 8"

MT-49

REVISION: 1      DATE: 7/14/09  
DESCRIPTION: SOFFIT "J"

MT-50

REVISION: 1      DATE: 7/14/09  
DESCRIPTION: 2" CAP TRIM

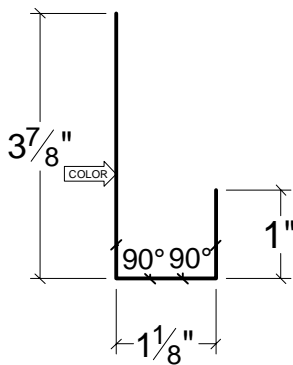

STRETCH OUT: 6"

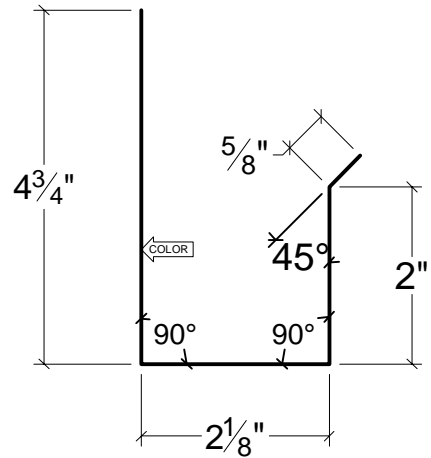

STRETCH OUT: 9 1/2"

MT-51

REVISION: 1      DATE: 7/14/09  
DESCRIPTION: 1" CAP TRIM

MT-52

REVISION: 1      DATE: 7/14/09  
DESCRIPTION: 2" CAP w/ CLEAT



DETAIL TYPE:

STANDARD TRIM

REVISION

DATE:

10

12/29/16

11

01/19/16

PANEL TYPE:

VARIES

PAGE NUMBER:

9

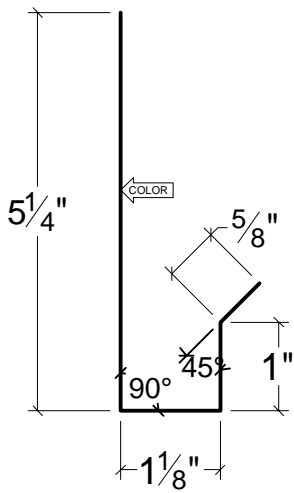

STRETCH OUT: 8"

MT-53

REVISION: 1 DATE: 7/14/09  
DESCRIPTION: 1" CAP w/ CLEAT

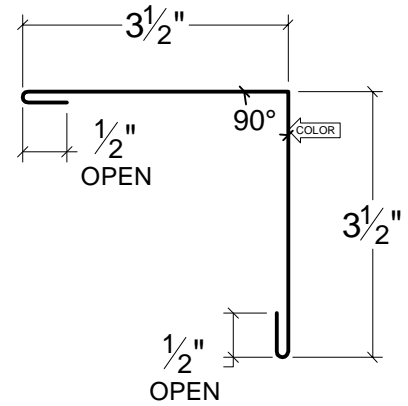

STRETCH OUT: 8"

MT-55

REVISION: 1 DATE: 7/14/09  
DESCRIPTION: OUTSIDE CORNER TRIM

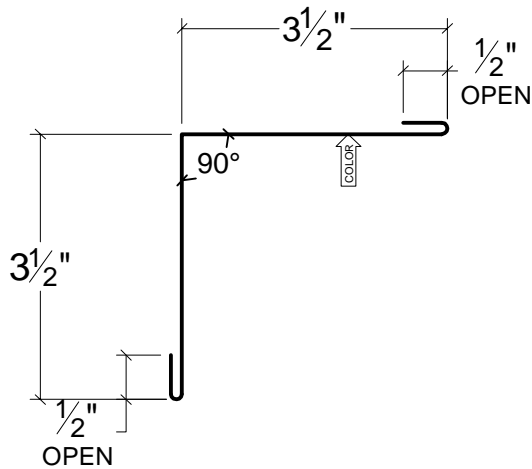

STRETCH OUT: 8"

MT-56

REVISION: 1 DATE: 7/14/09  
DESCRIPTION: INSIDE CORNER TRIM

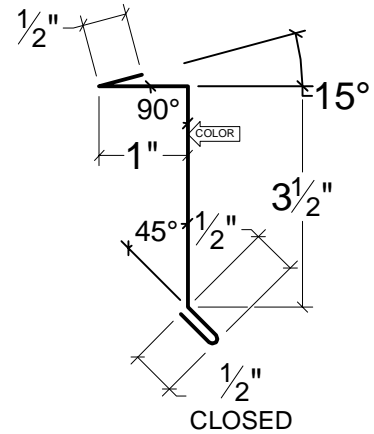

STRETCH OUT: 6"

MT-58

REVISION: 1 DATE: 7/14/09  
DESCRIPTION: STANDARD REGLET

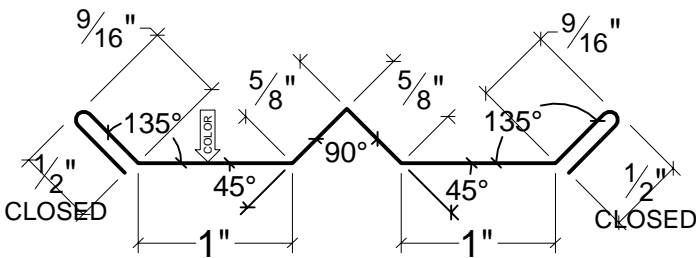

STRETCH OUT: 5 3/8"

MT-59

REVISION: 1 DATE: 7/14/09  
DESCRIPTION: COUNTER FLASHING

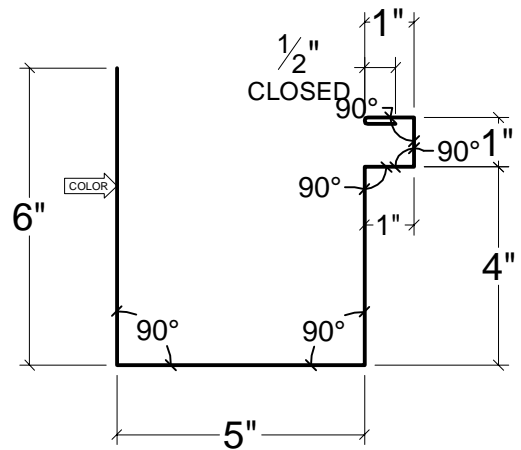

STRETCH OUT: 18 1/2"

MT-61

REVISION: 2 DATE: 10/26/11  
DESCRIPTION: GUTTER



DETAIL TYPE:

STANDARD TRIM

PANEL TYPE:

VARIES

REVISION

DATE:

10

12/29/16

11

01/19/16

PAGE NUMBER:

10

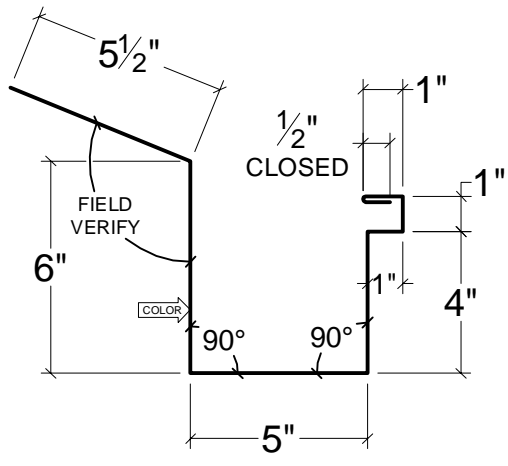

STRETCH OUT: 24"

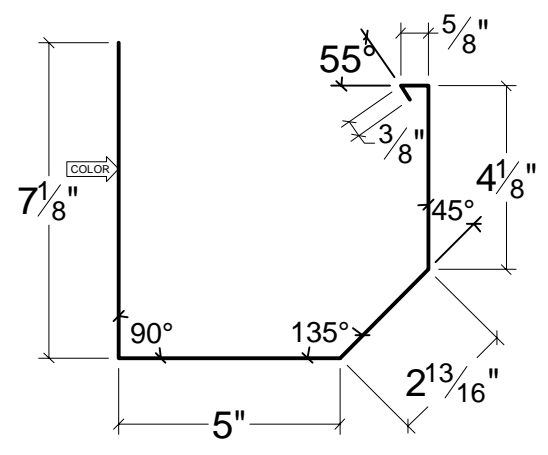

STRETCH OUT: 20 1/16"

MT-62

REVISION: 2 DATE: 10/26/11  
DESCRIPTION: GUTTER

MT-63B

REVISION: 2 DATE: 10/26/11  
DESCRIPTION: 7" BOX GUTTER

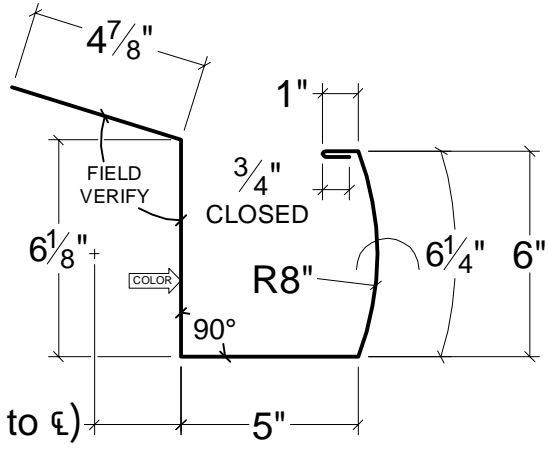

(2 7/16" to  $\phi$ )

HOUSTON PLANT ONLY

STRETCH OUT: 24"

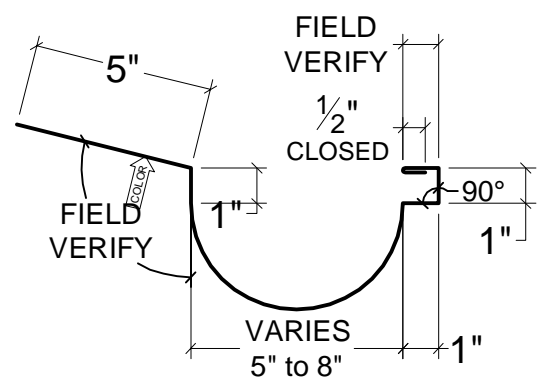

HOUSTON PLANT ONLY

STRETCH OUT: VARIES

MT-64

REVISION: 1 DATE: 7/14/09  
DESCRIPTION: ROUND FACE GUTTER

MT-65

REVISION: 2 DATE: 10/26/11  
DESCRIPTION: HALF ROUND GUTTER

1" CLOSED

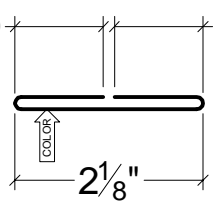

STRETCH OUT: 4 1/8" X 10"

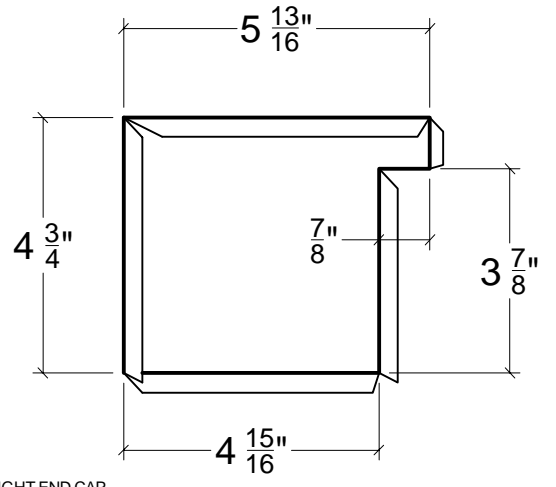

MT-68R= RIGHT END CAP  
MT-68L= LEFT END CAP

STRETCH OUT: STANDARD

MT-67

REVISION: 2 DATE: 05/23/14  
DESCRIPTION: GUTTER/DOWNSPOUT STRAP

MT-68

REVISION: 2 DATE: 11/4/15  
DESCRIPTION: GUTTER END CAP



DETAIL TYPE: STANDARD TRIM

PANEL TYPE: VARIES

REVISION	DATE:
10	12/29/16
11	01/19/16

PAGE NUMBER: 11

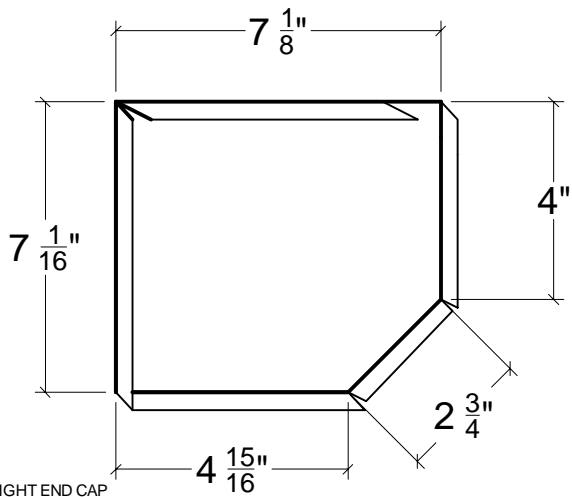

MT-69R= RIGHT END CAP  
 MT-69L= LEFT END CAP

STRETCH OUT: STANDARD

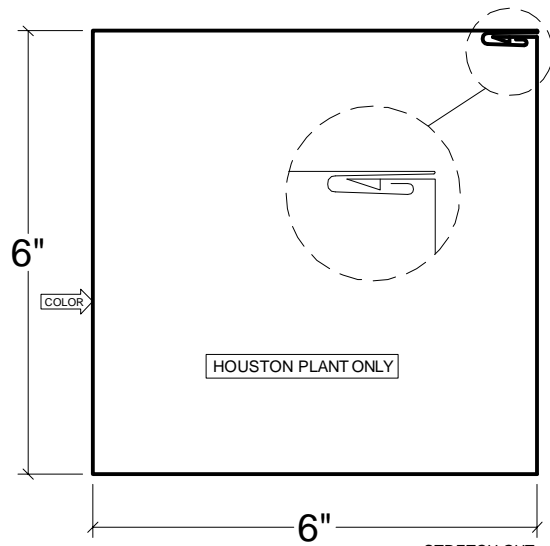

STRETCH OUT: 25 5/8"

MT-69B REVISION: 1 DATE: 7/14/09  
 DESCRIPTION: GUTTER END CAP (USE WITH MT-63B)

MT-71 REVISION: 3 DATE: 9/06/11  
 DESCRIPTION: 6" x 6" DOWNSPOUT

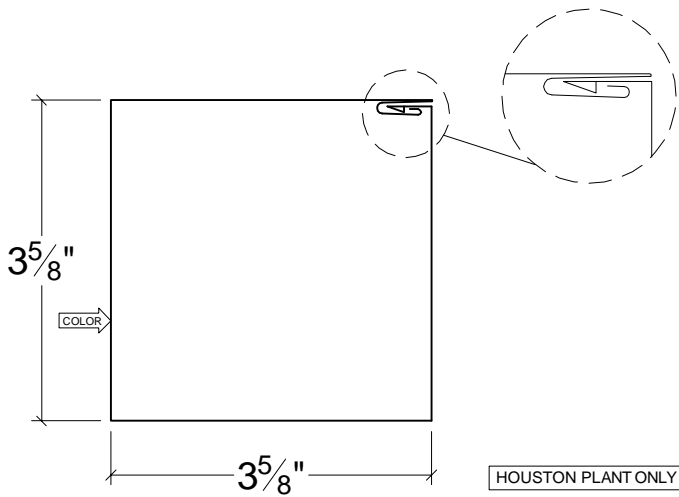

STRETCH OUT: 16 1/8"

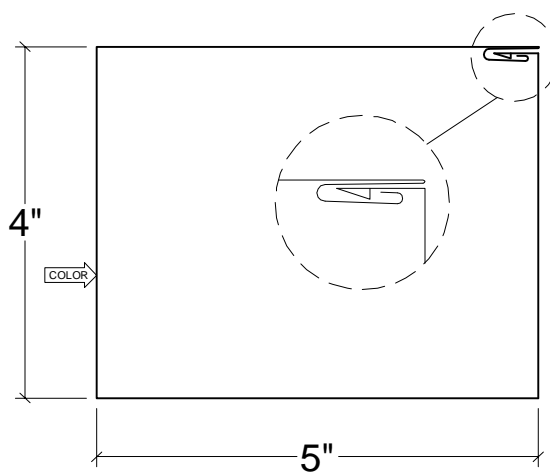

STRETCH OUT: 19 5/8"

MT-72 REVISION: 3 DATE: 9/06/11  
 DESCRIPTION: 3 5/8" x 3 5/8" DOWNSPOUT

MT-73 REVISION: 3 DATE: 9/06/11  
 DESCRIPTION: 4" x 5" DOWNSPOUT

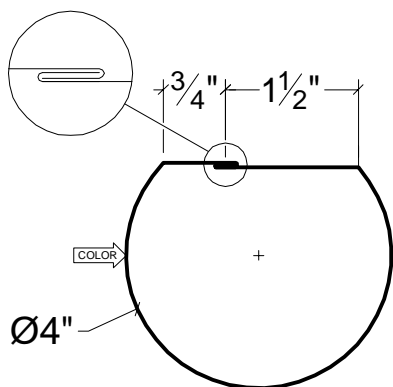

STRETCH OUT: 13 5/8"

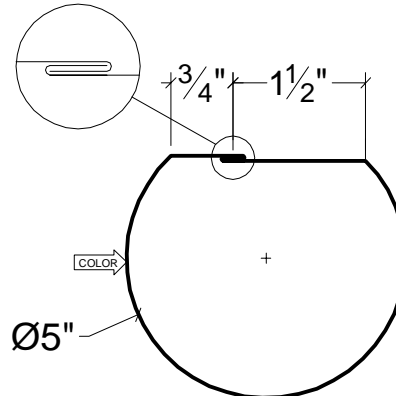

STRETCH OUT: 16 13/16"

MT-74A REVISION: 1 DATE: 7/14/09  
 DESCRIPTION: Ø4" CIRCULAR DOWNSPOUT

MT-74B REVISION: 1 DATE: 7/14/09  
 DESCRIPTION: Ø5" CIRCULAR DOWNSPOUT



DETAIL TYPE: **STANDARD TRIM**  
 PANEL TYPE: **VARIES**

REVISION	DATE:
10	12/29/16
11	01/19/16

PAGE NUMBER: **12**

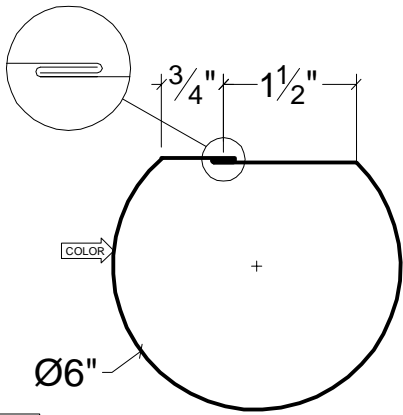

HOUSTON PLANT ONLY

STRETCH OUT: 19 15/16"

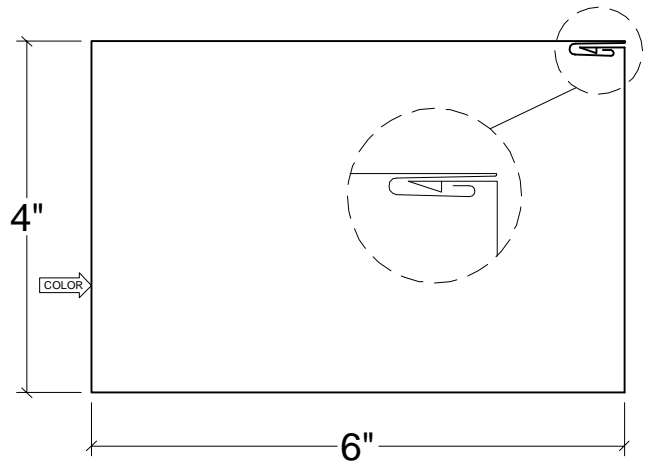

HOUSTON PLANT ONLY

STRETCH OUT: 21 5/8"

MT-74C

REVISION: 1      DATE: 7/14/09  
DESCRIPTION: Ø6" CIRCULAR DOWNSPOUT

MT-75

REVISION: 3      DATE: 9/06/11  
DESCRIPTION: 4" x 6" DOWNSPOUT

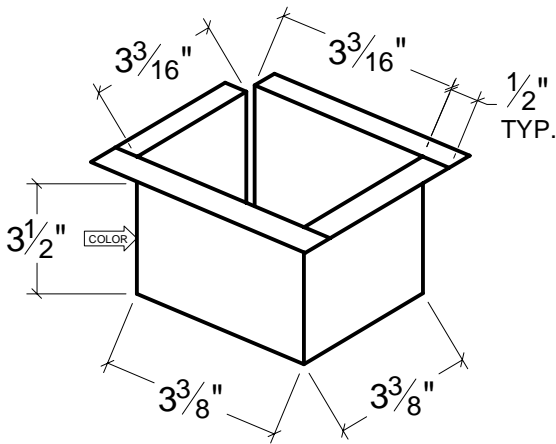

STRETCH OUT: 13 1/8"

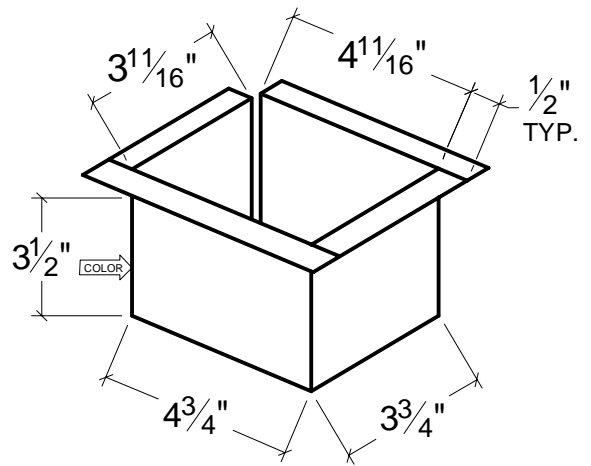

STRETCH OUT: 16 7/8"

MT-77

REVISION: 2      DATE: 06/22/12  
DESCRIPTION: DOWNSPOUT

MT-78

REVISION: 2      DATE: 06/22/12  
DESCRIPTION: DOWNSPOUT SLEEVE

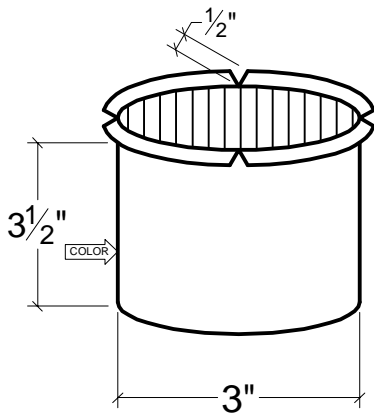

HOUSTON PLANT ONLY

STRETCH OUT: VARIES

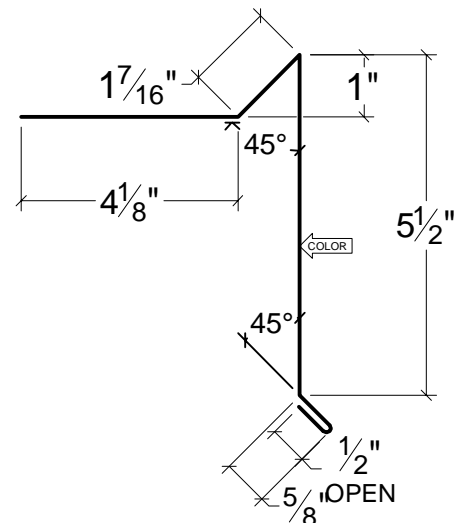

STRETCH OUT: 12 3/16"

MT-79

REVISION: 1      DATE: 7/14/09  
DESCRIPTION: CIRCULAR SLEEVE

MT-80

REVISION: 3      DATE: 06/22/12  
DESCRIPTION: GRAVEL GUARD



DETAIL TYPE:

STANDARD TRIM

REVISION

DATE:

00

12/29/18

01

03/11/2019

PANEL TYPE:

VARIES

PAGE NUMBER:

13

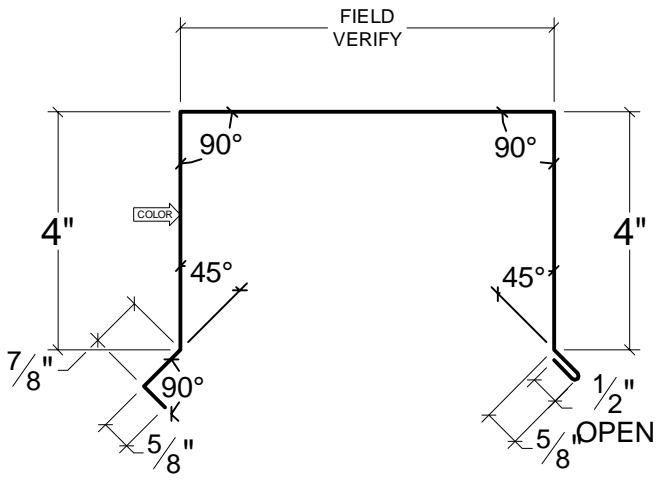

STRETCH OUT: VARIES

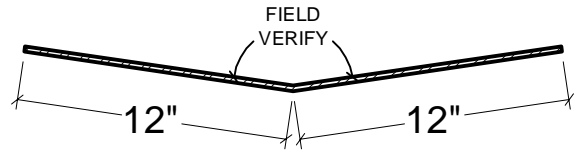

HOUSTON PLANT ONLY

16 Ga. GALVANIZED  
AVAILABLE IN 10'-0" LENGTHS ONLY

STRETCH OUT: 24"

MT-81 REVISION: 1 DATE: 7/14/09  
DESCRIPTION: PARAPET CAP TRIM

MT-84 REVISION: 1 DATE: 5/28/14  
DESCRIPTION: RIDGE/HIP/VALLEY PLATE

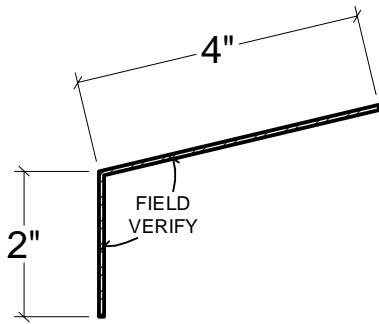

16 Ga. GALVANIZED  
AVAILABLE IN 10'-0" LENGTHS ONLY

STRETCH OUT: 6"

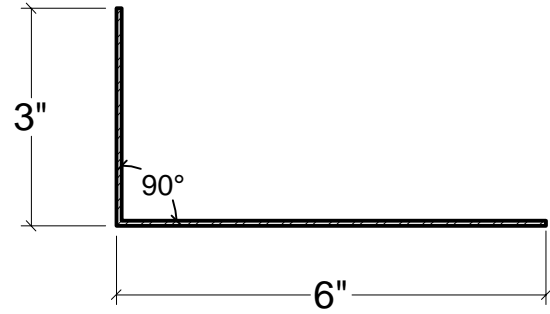

16 Ga. GALVANIZED  
AVAILABLE IN 10'-0" LENGTHS ONLY

STRETCH OUT: 9"

MT-85 REVISION: 1 DATE: 7/14/09  
DESCRIPTION: EAVE ANGLE

MT-87 REVISION: 1 DATE: 7/14/09  
DESCRIPTION: BACK-UP PLATE

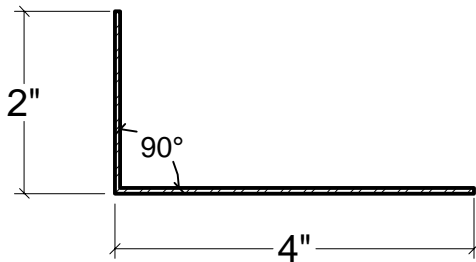

16 Ga. GALVANIZED  
AVAILABLE IN 10'-0" LENGTHS ONLY

STRETCH OUT: 6"

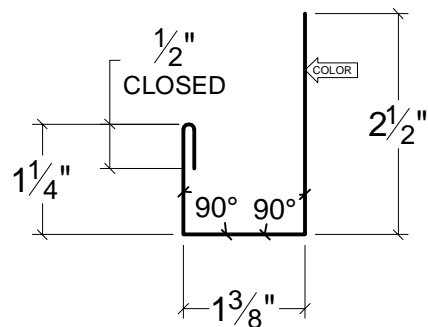

STRETCH OUT: 5 5/8"

MT-88 REVISION: 1 DATE: 7/14/09  
DESCRIPTION: RAKE ANGLE

MT-119 REVISION: 1 DATE: 7/14/09  
DESCRIPTION: HEAD TRIM



DETAIL TYPE:

STANDARD TRIM

REVISION

DATE:

10

12/29/18

11

03/11/19/1/19

PANEL TYPE:

VARIES

PAGE NUMBER:

14

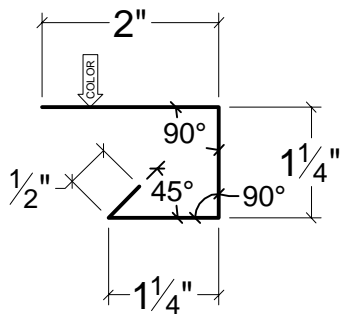

STRETCH OUT: 5"

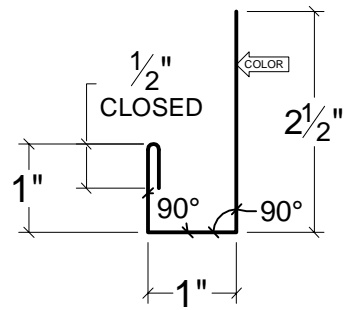

STRETCH OUT: 5"

MT-120

REVISION: 1

DATE: 7/14/09

DESCRIPTION: JAMB TRIM

MT-131

REVISION: 1

DATE: 7/14/09

DESCRIPTION: HEAD TRIM

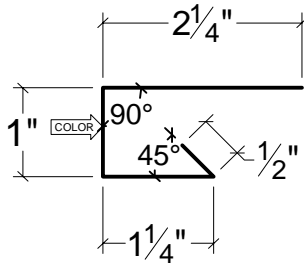

STRETCH OUT: 5"

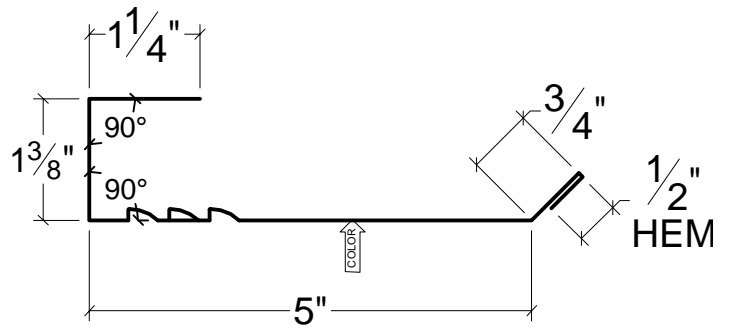

PERFORATIONS DIFFERENT AT HOUSTON PLANT

USE WITH MT-3 VENTED RIDGE CAP

& MT-154 VENTED HEADWALL

STRETCH OUT: 8 7/8"

MT-132

REVISION: 1

DATE: 7/14/09

DESCRIPTION: JAMB TRIM

MT-133

REVISION: 2

DATE: 6/18/13

DESCRIPTION: PERFORATED "J" CHANNEL

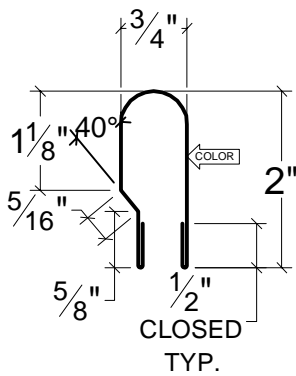

HOUSTON PLANT ONLY

STRETCH OUT: 5 1/4"

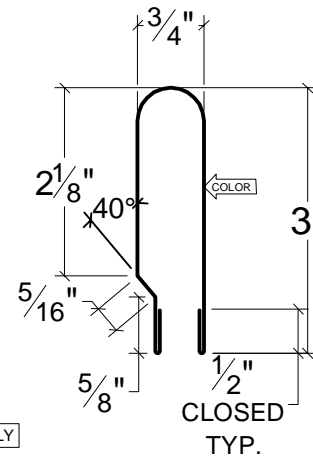

HOUSTON PLANT ONLY

STRETCH OUT: 7 1/2"

MT-143

REVISION: 2

DATE: 06/22/12

DESCRIPTION: 200 SEAM REPAIR CAP

MT-144

REVISION: 2

DATE: 06/22/12

DESCRIPTION: 300 SEAM REPAIR CAP



DETAIL TYPE:

STANDARD TRIM

REVISION

DATE:

10

12/29/16

11

01/19/16

PANEL TYPE:

VARIES

PAGE NUMBER:

15



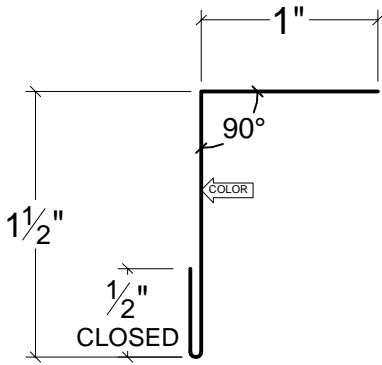

STRETCH OUT: 3"

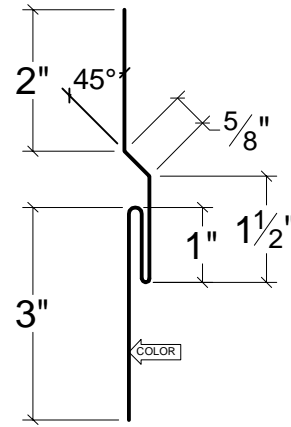

STRETCH OUT: 8 1/8"

MT-145 REVISION: 1 DATE: 7/14/09  
DESCRIPTION: RAKE CLEAT

MT-146 REVISION: 2 DATE: 9/06/11  
DESCRIPTION: RECEIVER

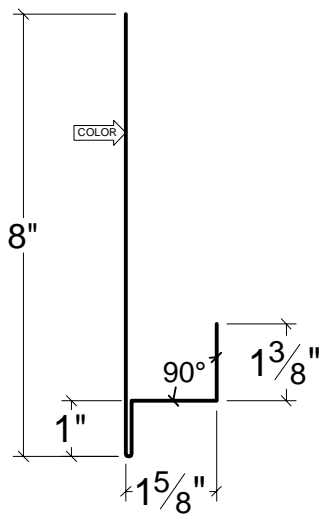

STRETCH OUT: 12"

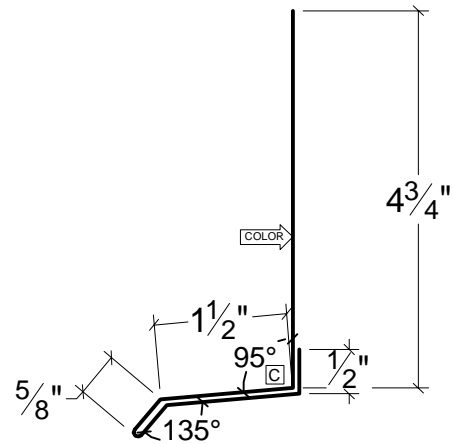

STRETCH OUT: 9 1/2"

MT-147 REVISION: 1 DATE: 7/14/09  
DESCRIPTION: FASCIA WRAP

MT-148 REVISION: 2 DATE: 9/06/11  
DESCRIPTION: 1 1/2" SILL w/ RETURN

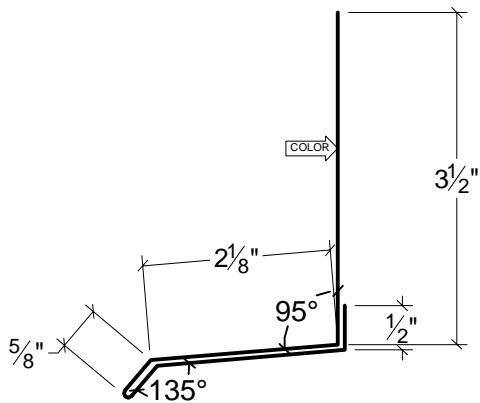

STRETCH OUT: 9 1/2"

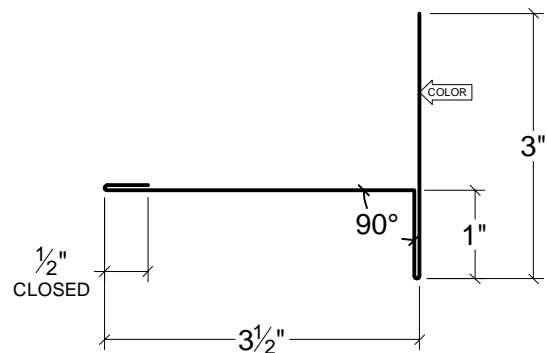

STRETCH OUT: 8"

MT-149 REVISION: 2 DATE: 9/06/11  
DESCRIPTION: 2" SILL w/ RETURN

MT-150 REVISION: 1 DATE: 7/14/09  
DESCRIPTION: FASCIA/SOFFIT TRIM



DETAIL TYPE:  
**STANDARD TRIM**

PANEL TYPE:  
**VARIES**

REVISION	DATE:
10	12/29/16
11	01/19/16

PAGE NUMBER:  
**16**

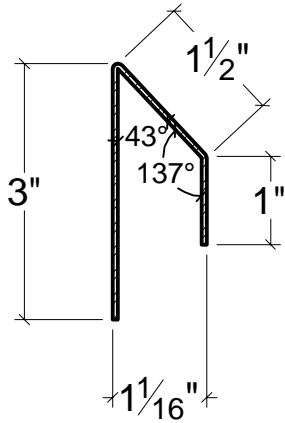

16 Ga. GALVANIZED  
AVAILABLE IN 10'-0" LENGTHS ONLY

STRETCH OUT: 5 1/2"

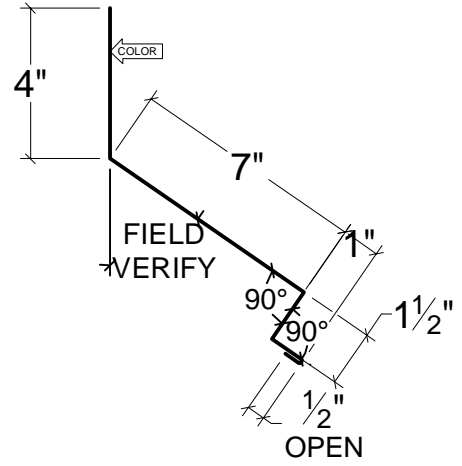

USE WITH MT-133 PERFORATED "J" CHANNEL

STRETCH OUT: 14"

MT-153

REVISION: 1 DATE: 7/14/09  
DESCRIPTION: FLUSH PANEL OIL CANNING PREVENTER

MT-154

REVISION: 1 DATE: 7/14/09  
DESCRIPTION: VENTED HEADWALL

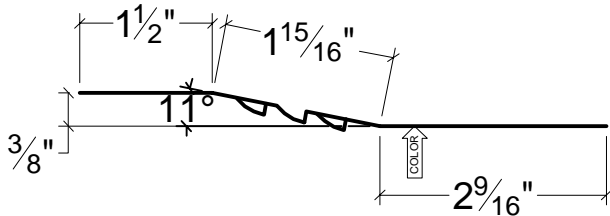

PERFORATIONS DIFFERENT AT HOUSTON PLANT

STRETCH OUT: 6"

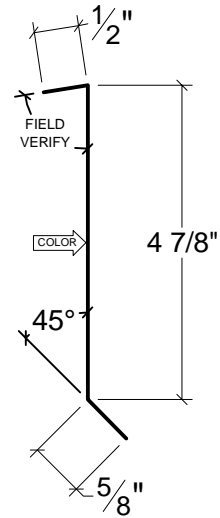

STRETCH OUT: 6

MT-155

REVISION: 1 DATE: 7/14/09  
DESCRIPTION: PERFORATED OFFSET CLEAT

MT-156

REVISION: 1 DATE: 3/12/13  
DESCRIPTION: RAKE SUPPORT CLEAT

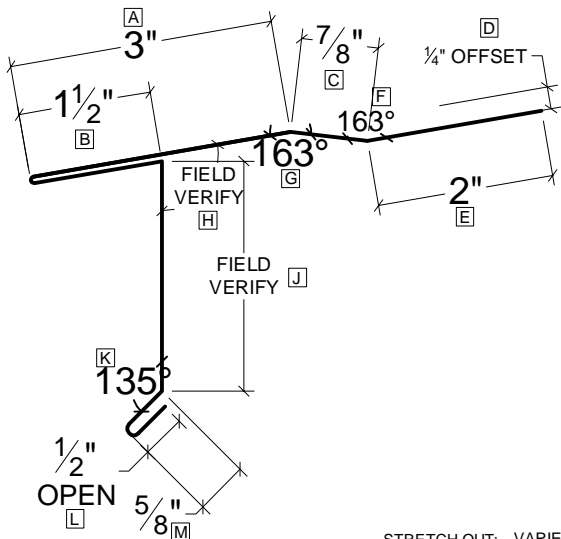

STRETCH OUT: VARIES

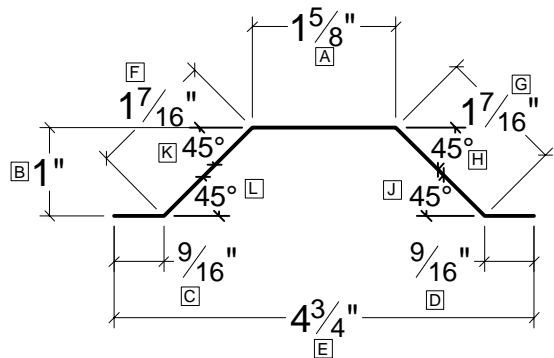

NOTE!  
MEMBER IS ROLL FORMED AND  
THE DIMENSIONS ARE FINAL  
16Ga. GALVANIZED

STRETCH OUT: 5 5/8"

MT-157

REVISION: 1 DATE: 02/18/11  
DESCRIPTION: 238 STANDARD EAVE / RAKE OFFSET FLASHING

AI-HAT-1.0

REVISION: 2 DATE: 9/06/11  
DESCRIPTION: 8/06/11



DETAIL TYPE:

STANDARD TRIM

REVISION

DATE:

10

12/29/16

11

01/19/16

PANEL TYPE:

VARIES

PAGE NUMBER:

17

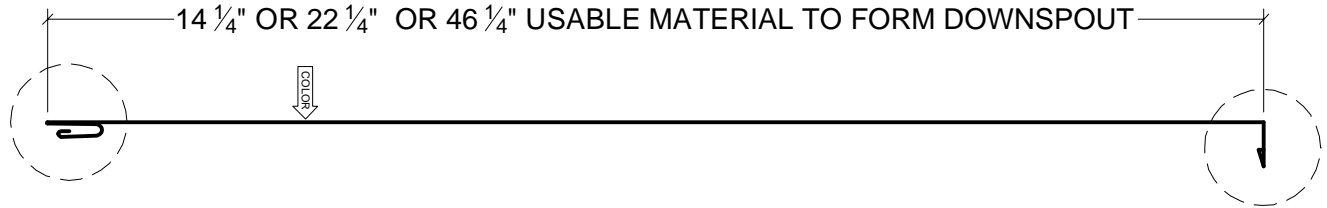
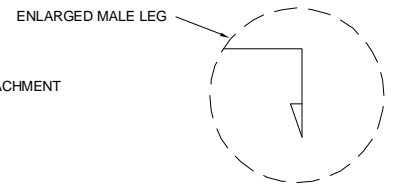
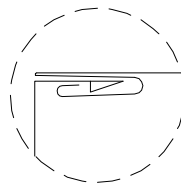
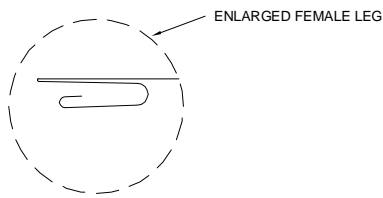

**PARTIALLY FORMED DOWNSPOUT**

MINIMUM LENGTH 10'-0", MAXIMUM LENGTH DETERMINED BY CUSTOMERS  
 LENGTH OF FIELD BREAK, ABC MAXIMUM LENGTH IS 30'-0"

STRETCH OUT: 16", 24", OR 48"

MT-DSSTRP	REVISION: 2	DATE: 4/22/10
	DESCRIPTION: PARTIALLY FORMED DOWNSPOUT	

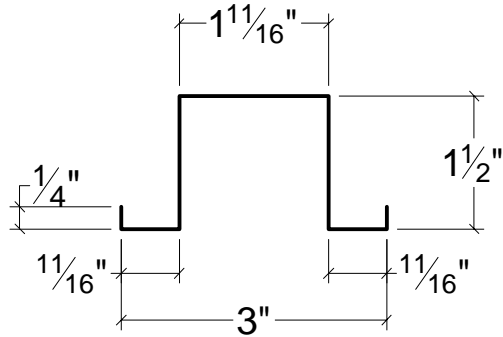

NOTE:  
 MEMBER IS ROLL FORMED AND  
 THE DIMENSIONS ARE FINAL  
 16Ga. GALVANIZED

STRETCH OUT: 6 9/16"

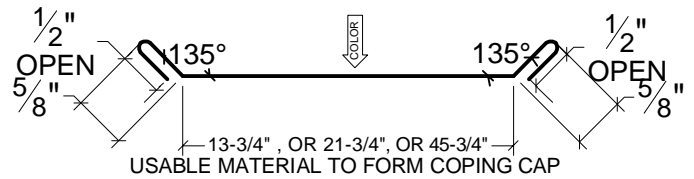

**PARTIALLY FORMED COPING CAP W/ TWO OPEN HEMS**

MINIMUM LENGTH 10'-0", MAXIMUM LENGTH DETERMINED BY CUSTOMERS  
 LENGTH OF FIELD BREAK, ABC MAXIMUM LENGTH IS 30'-0"

STRETCH OUT: 16", 24", OR 48"

AL-HAT-1.5	REVISION: 0	DATE: 7/14/09	MT-COPSTRP	REVISION: 2	DATE: 4/22/10
	DESCRIPTION: HAT CHANNEL HS-1			DESCRIPTION: PARTIALLY FORMED COPING CAP	

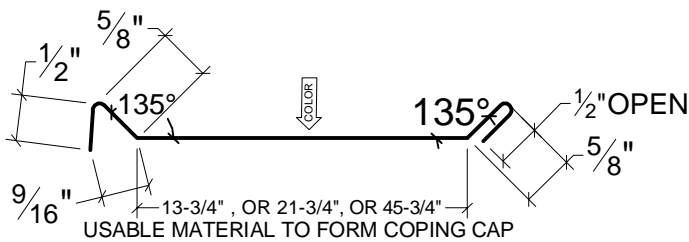

**PARTIALLY FORMED COPING CAP W/ ONE WIDE OPEN LEG & ONE OPEN HEM**  
 MINIMUM LENGTH 10'-0", MAXIMUM LENGTH DETERMINED BY CUSTOMERS  
 LENGTH OF FIELD BREAK, ABC MAXIMUM LENGTH IS 30'-0"

STRETCH OUT: 16", 24", OR 48"

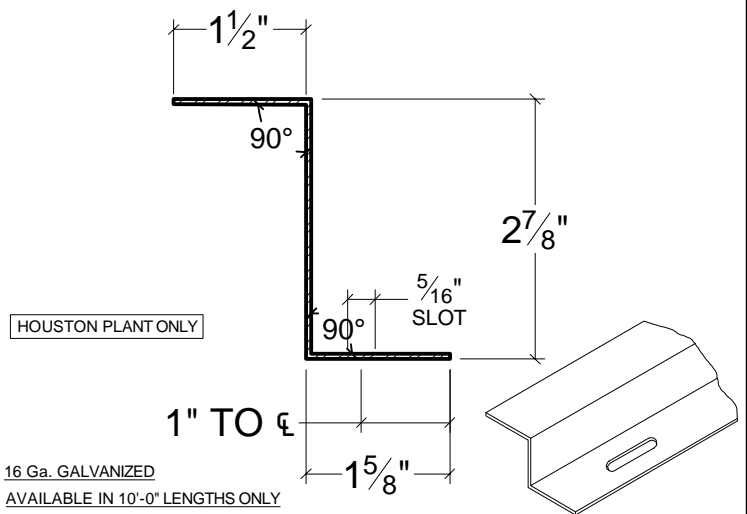

HOUSTON PLANT ONLY

16 Ga. GALVANIZED

AVAILABLE IN 10'-0" LENGTHS ONLY

SLOTS ARE 4 5/16" x 5/16" @ 12" O.C.

STRETCH OUT: 5 15/16"

MT-COPSTRP-B	REVISION: 2	DATE: 4/22/10	MT-SLOT-Z238	REVISION: 5	DATE: 05/27/14
	DESCRIPTION: PARTIALLY FORMED COPING CAP W/ ONE WIDE OPEN LEG			DESCRIPTION: SPECIAL 16GA. SLOTTED ZEE	



DETAIL TYPE: <b>STANDARD TRIM</b>	REVISION	DATE:
	10	12/29/16
	11	01/19/16
PANEL TYPE: <b>VARIES</b>	PAGE NUMBER: <b>18</b>	

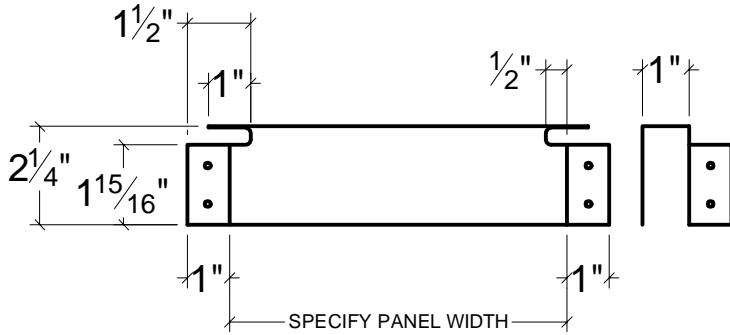

HOUSTON PLANT ONLY

USE WITH PRE-FABRICATED  
FOAM INSERT

STRETCH OUT: 5 1/2"  
STRETCH OUT: LENGTH VARIES

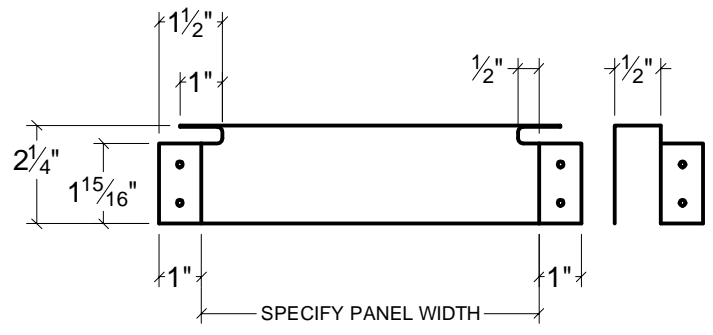

HOUSTON PLANT ONLY

USE WITH PRE-FABRICATED  
FOAM INSERT

STRETCH OUT: 5 1/2"  
STRETCH OUT: LENGTH VARIE

MT-238T-CLOS REVISION: 1 DATE: 6/18/2010  
DESCRIPTION: 238T METAL CLOSURE @ RIDGE

MT-238T-CLOS-HIP REVISION: 2 DATE: 12/29/15  
DESCRIPTION: 238T METAL CLOSURE @ HIP

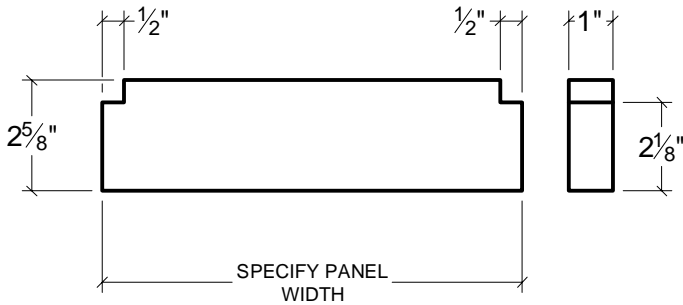

USE WITH PRE-FABRICATED  
METAL CLOSURES

STRETCH OUT: VARIES

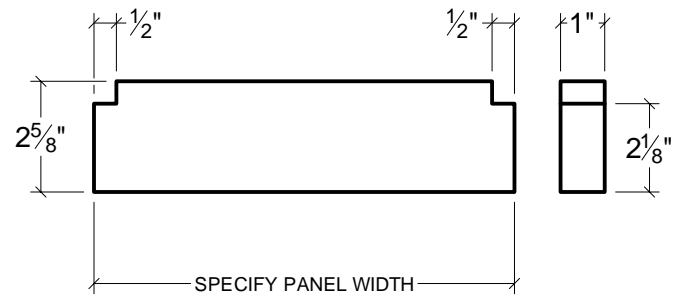

USE WITH PRE-FABRICATED  
METAL CLOSURES

STRETCH OUT: VARIES

AI-CLOS-238T REVISION: 1 DATE: 10/14/10  
DESCRIPTION: 238T FOAM INSERT FOR METAL CLOSURE @ RIDGE

AI-CLOS-238T-HIP REVISION: 2 DATE: 12/29/15  
DESCRIPTION: 238T FOAM INSERT FOR METAL CLOSURE @ HIP

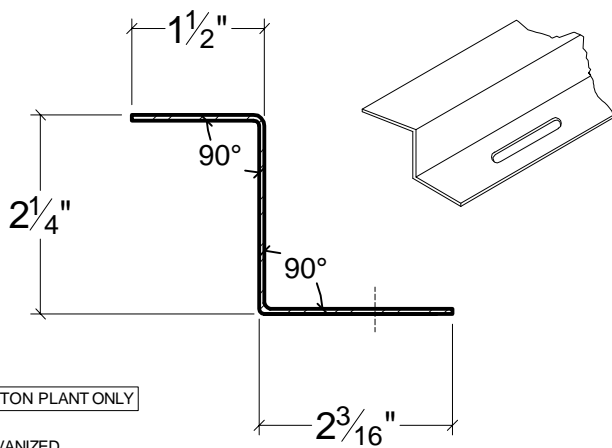

HOUSTON PLANT ONLY

16GA. GALVANIZED  
AVAILABLE IN 10'-0" LENGTHS ONLY  
SLOTS ARE 4-1/4" x 1/4" @ 12" O.C.

STRETCH OUT: 5-15/16"

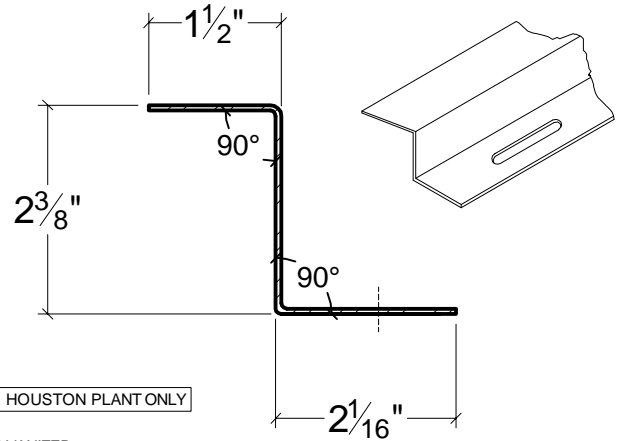

HOUSTON PLANT ONLY

16 Ga. GALVANIZED  
AVAILABLE IN 10'-0" LENGTHS ONLY  
SLOTS ARE 4-1/4" x 1/4" @ 12" O.C.

STRETCH OUT: 5-15/16"

MT-SLOT-Z200-1/4 REVISION: 0 DATE: 03/09/10  
DESCRIPTION: STARTER ZEE FOR 200 PANEL W/1/4" OFFSET CLIP

MT-SLOT-Z200-3/8 REVISION: 0 DATE: 03/09/10  
DESCRIPTION: STARTER ZEE FOR 200 PANEL W/3/8" OFFSET CLIP



DETAIL TYPE:  
**STANDARD TRIM**

REVISION	DATE:
10	12/29/16
11	01/19/16

PANEL TYPE:  
**VARIES**

PAGE NUMBER:  
**19**

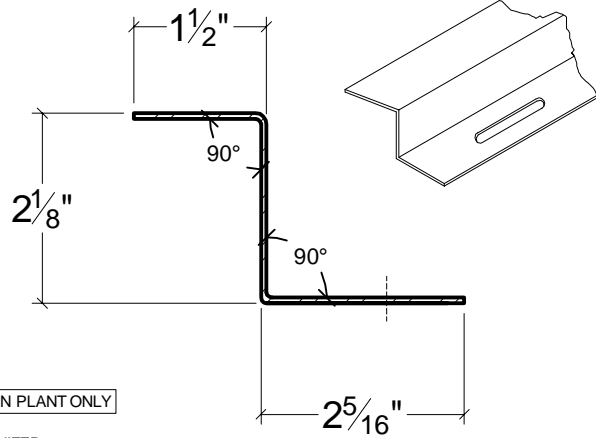

HOUSTON PLANT ONLY

16 Ga. GALVANIZED  
 AVAILABLE IN 10'-0" LENGTHS ONLY  
 SLOTS ARE 4-1/4" x 1/4" @ 12" O.C.

STRETCH OUT: 5-15/16"

MT-SLOT-Z200	REVISION: 0	DATE: 03/09/10
	DESCRIPTION: STARTER ZEE FOR 200 PANEL W/2-1/8" UTILITY CLIP	

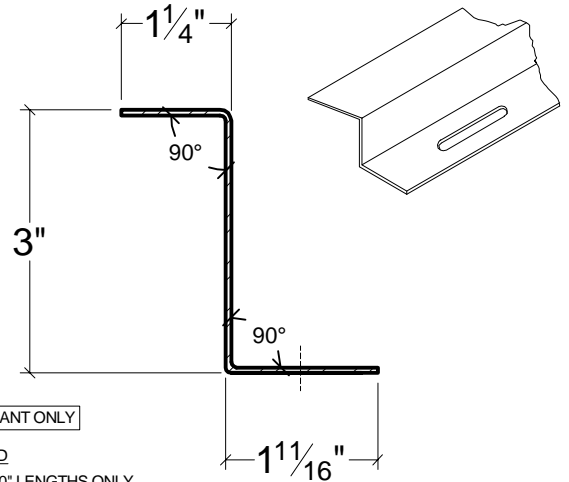

HOUSTON PLANT ONLY

16 Ga. GALVANIZED  
 AVAILABLE IN 10'-0" LENGTHS ONLY  
 SLOTS ARE 4-1/4" x 1/4" @ 12" O.C.

STRETCH OUT: 5-15/16"

MT-SLOTZ200-1	REVISION: 0	DATE: 03/09/10
	DESCRIPTION: STARTER ZEE FOR 200 PANEL W/1" OFFSET CLIP	

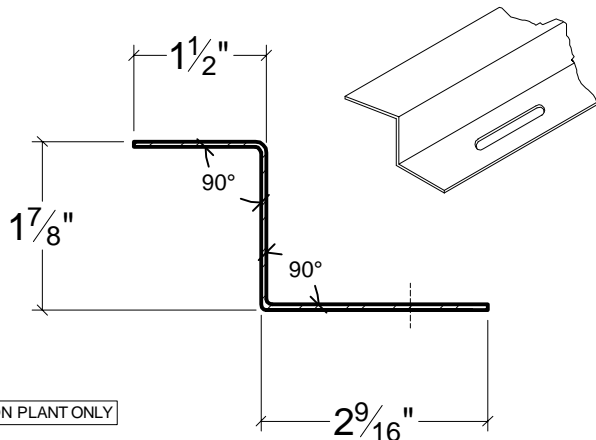

HOUSTON PLANT ONLY

16 Ga. GALVANIZED  
 AVAILABLE IN 10'-0" LENGTHS ONLY  
 SLOTS ARE 4-1/4" x 1/4" @ 12" O.C.

STRETCH OUT: 5-15/16"

MTSLOT-ZPM	REVISION: 0	DATE: 03/09/10
	DESCRIPTION: STARTER ZEE FOR PERMASEAM PANEL	

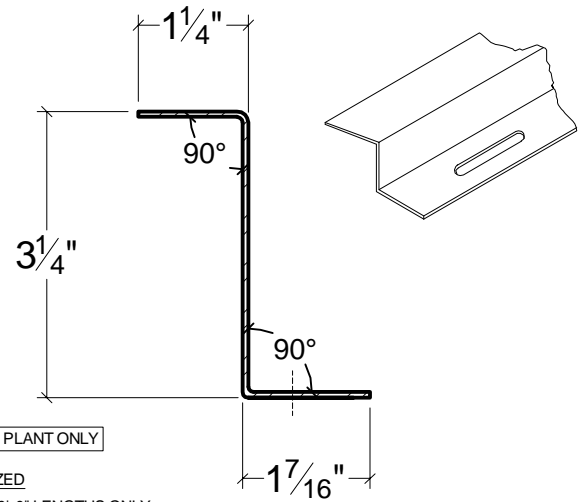

HOUSTON PLANT ONLY

16 Ga. GALVANIZED  
 AVAILABLE IN 10'-0" LENGTHS ONLY  
 SLOTS ARE 4-1/4" x 1/4" @ 12" O.C.

STRETCH OUT: 5-15/16"

MT-SLOTZ300	REVISION: 0	DATE: 01/19/11
	DESCRIPTION: STARTER ZEE FOR 300 PANEL W/1/4" OFFSET CLIP	

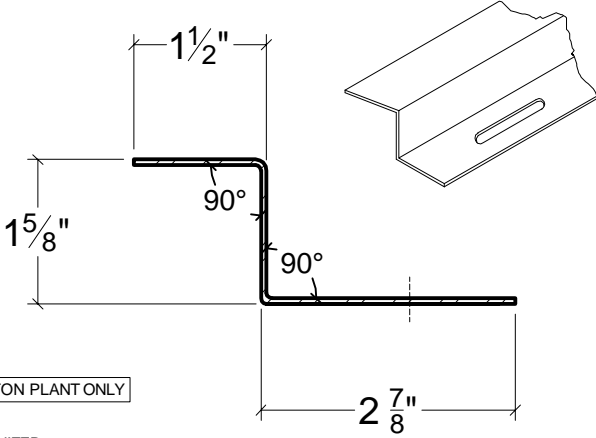

HOUSTON PLANT ONLY

16 Ga. GALVANIZED  
 AVAILABLE IN 10'-0" LENGTHS ONLY  
 SLOTS ARE 4-1/4" x 1/4" @ 12" O.C.

STRETCH OUT: 6"

MT-SLOT-Z138T	REVISION: 1	DATE: 04/04/13
	DESCRIPTION: SPEC. 16GA. SLOTTED ZEE FOR 138T PANEL W/1-5/8" UTILITY CLIP	

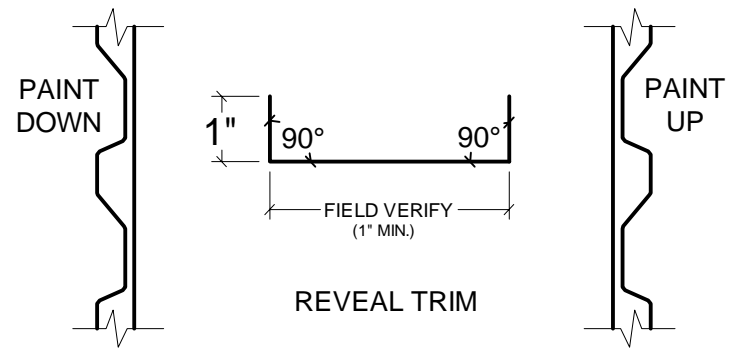

(PRE-NOTCHED) TRIM  
 SOLD IN 10'-0"  
 LENGTHS ONLY

HOUSTON PLANT ONLY

STRETCH OUT: 3" (MIN.)

MT-171	REVISION: 2	DATE: 11/24/15
	DESCRIPTION: FLAT TRIM without REVEAL - NOTCHED	



DETAIL TYPE:

STANDARD TRIM

REVISION

DATE:

10

12/29/16

11

01/19/16

PANEL TYPE:

VARIES

PAGE NUMBER:

20

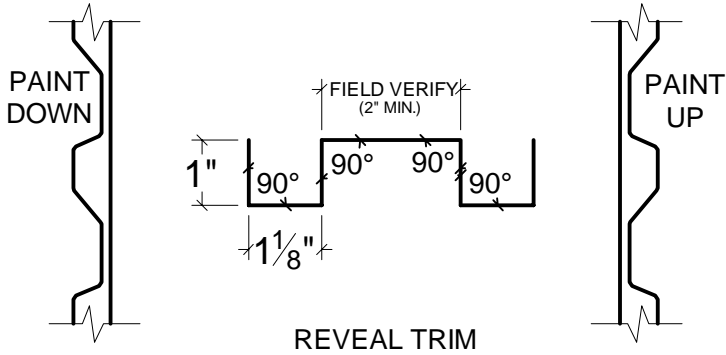

(PRE-NOTCHED) TRIM  
SOLD IN 10'-0"  
LENGTHS ONLY

HOUSTON PLANT ONLY

STRETCH OUT: 8 1/8" (MIN.)

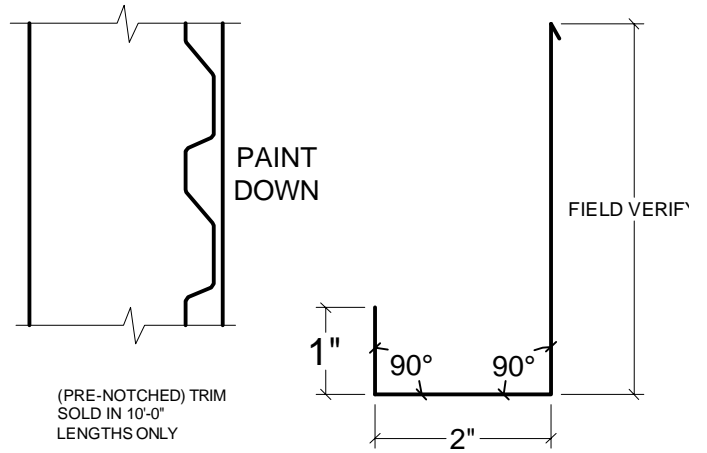

(PRE-NOTCHED) TRIM  
SOLD IN 10'-0"  
LENGTHS ONLY

HOUSTON PLANT ONLY

STRETCH OUT: VARIES

MT-172 REVISION: 2 DATE: 11/24/15  
DESCRIPTION: VERTICAL REVEAL TRIM - NOTCHED

MT-173-L REVISION: 1 DATE: 03/08/13  
DESCRIPTION: JAMB TRIM - NOTCHED (LEFT)

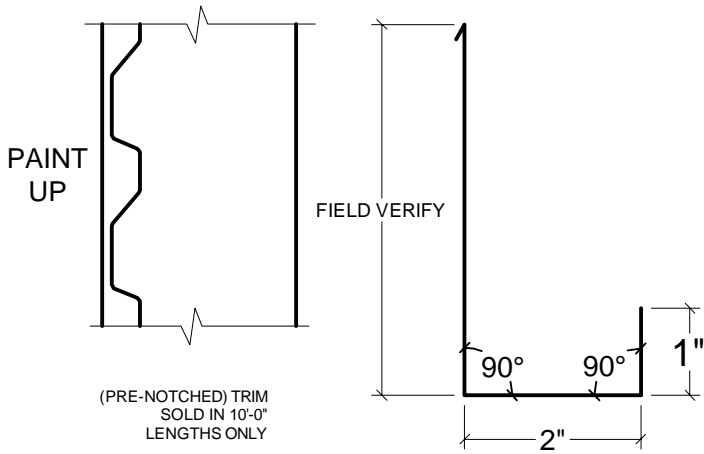

(PRE-NOTCHED) TRIM  
SOLD IN 10'-0"  
LENGTHS ONLY

HOUSTON PLANT ONLY

STRETCH OUT: VARIES

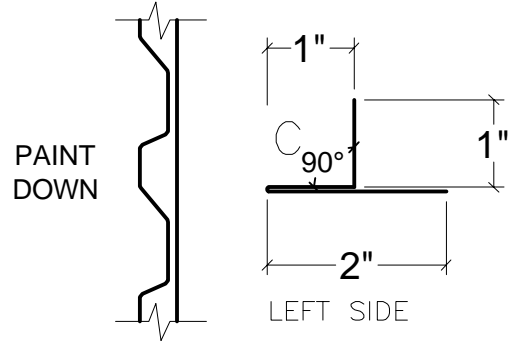

HOUSTON PLANT ONLY

STRETCH OUT: 4"

MT-173-R REVISION: 1 DATE: 03/08/13  
DESCRIPTION: JAMB TRIM - NOTCHED (RIGHT)

MT-174 REVISION: 1 DATE: 03/08/13  
DESCRIPTION: OUTSIDE CORNER CLEAT - NOTCHED (LEFT)

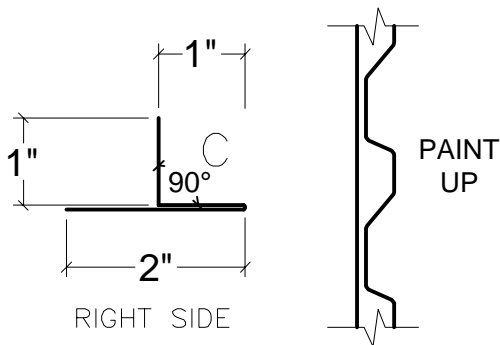

HOUSTON PLANT ONLY

STRETCH OUT: 4"

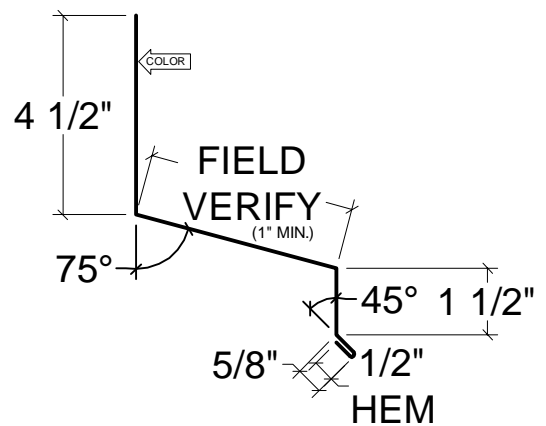

STRETCH OUT: 8 1/8" (MIN.)

MT-175 REVISION: 1 DATE: 03/08/13  
DESCRIPTION: OUTSIDE CORNER CLEAT - NOTCHED (RIGHT)

MT-176 REVISION: 1 DATE: 11/24/15  
DESCRIPTION: WAINSCOAT TRIM



DETAIL TYPE:  
**STANDARD TRIM**

REVISION	DATE:
10	12/29/16
11	01/19/16

PANEL TYPE:  
**VARIES**

PAGE NUMBER:  
**21**

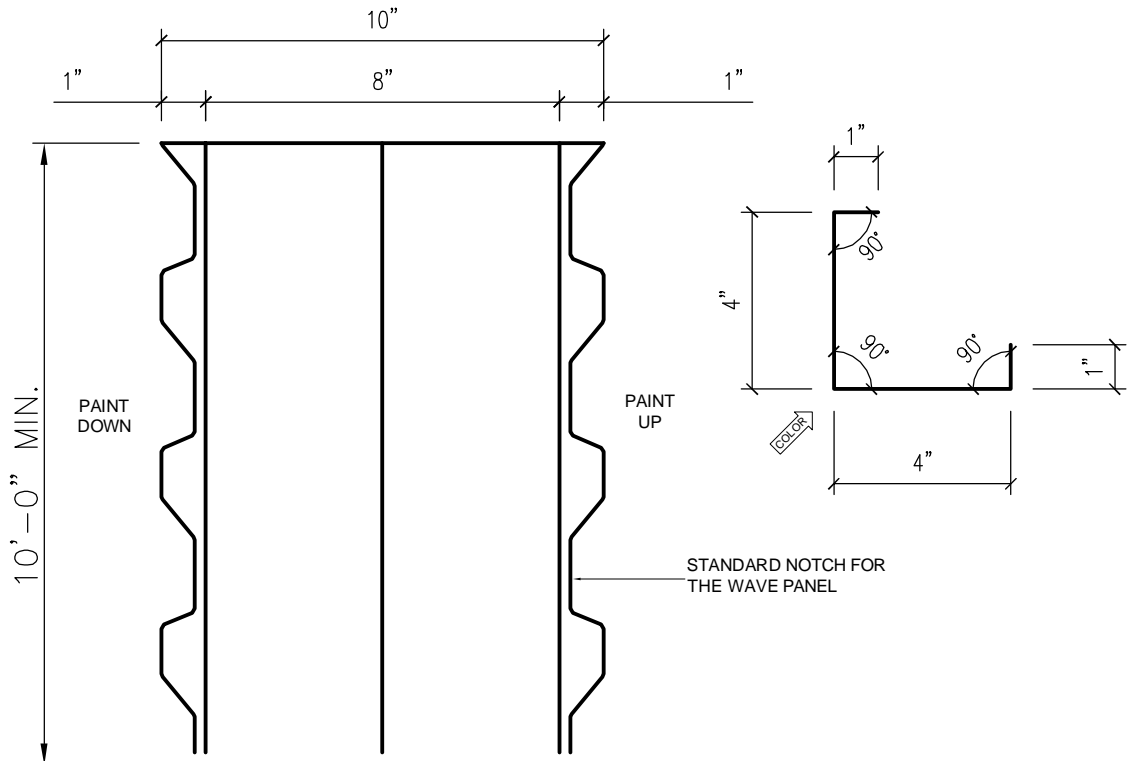

HOUSTON PLANT ONLY

STRETCH OUT: 10"

MT-WAV-CRN -OS-STD	REVISION: 1	DATE: 03/08/13
	DESCRIPTION: OUTSIDE CORNER TRIM - NOTCHED (WAVE PANEL)	

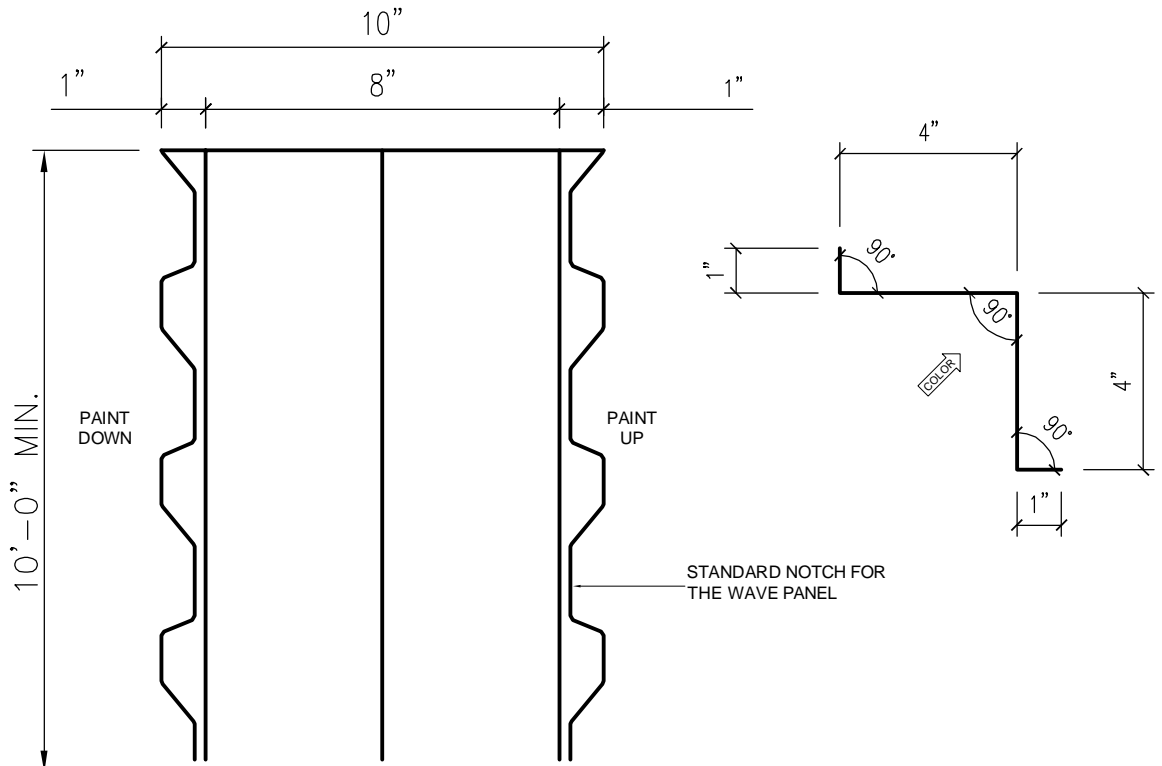

HOUSTON PLANT ONLY

STRETCH OUT: 10"

MT-WAV-CRN -IS-STD	REVISION: 1	DATE: 03/08/13
	DESCRIPTION: INSIDE CORNER TRIM - NOTCHED (WAVE PANEL)	

DETAIL TYPE:	STANDARD TRIM	
	REVISION	DATE:
PANEL TYPE:	10	12/29/15
	11	01/20/16
	PAGE NUMBER:	22



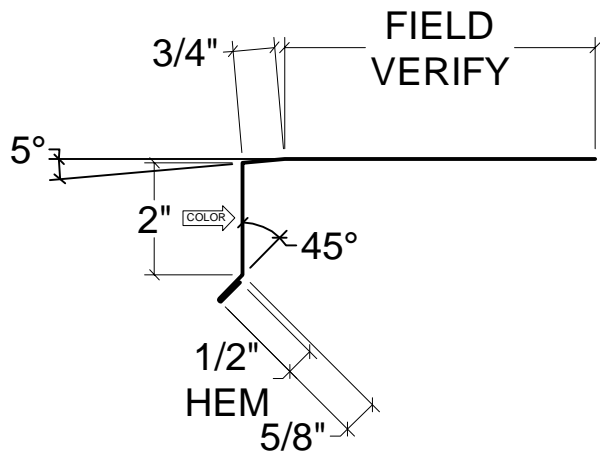

STRETCH OUT: T.B.D.

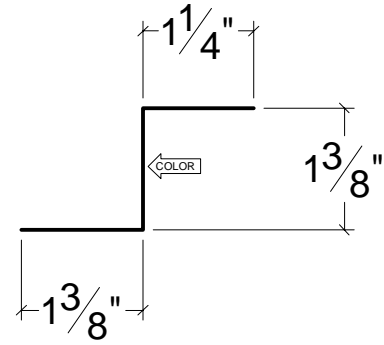

STRETCH OUT: 4"

MT-177 REVISION: 0 DATE: 3/07/13  
DESCRIPTION: 2" SILL TRIM

MT-178 REVISION: 0 DATE: 03/01/13  
DESCRIPTION: FW SERIES ZEE CLOSURE

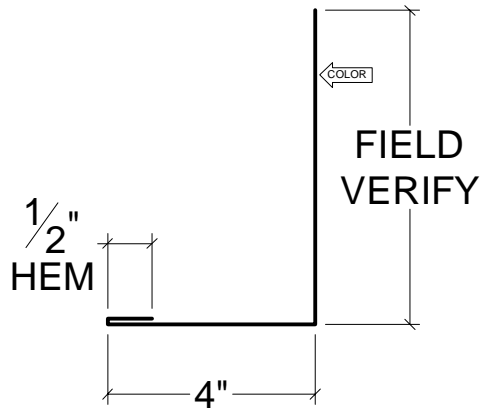

STRETCH OUT: T.B.D.

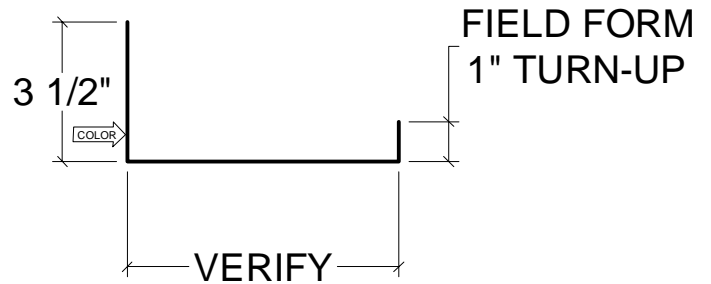

STRETCH OUT: T.B.D.

MT-179 REVISION: 0 DATE: 03/01/13  
DESCRIPTION: JAMB TRIM

MT-180 REVISION: 0 DATE: 03/01/13  
DESCRIPTION: HEAD TRIM

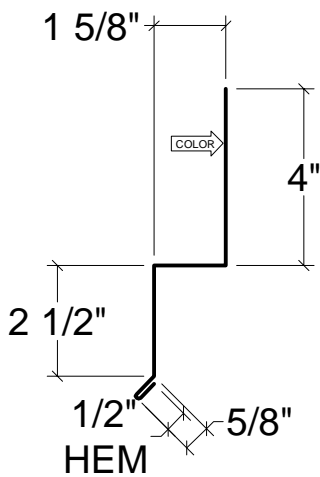

STRETCH OUT: 9 1/4"

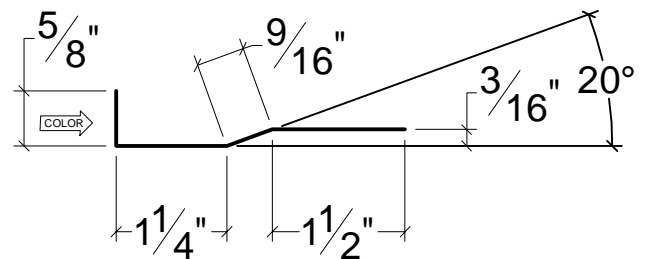

STRETCH OUT: 3 15/16"

MT-181 REVISION: 0 DATE: 03/01/13  
DESCRIPTION: ZEE SILL TRIM

MT-182 REVISION: 0 DATE: 03/04/13  
DESCRIPTION: FW SERIES FASTENER CLEAT



DETAIL TYPE:  
**STANDARD TRIM**

REVISION	DATE:
10	12/29/16
11	01/19/16

PANEL TYPE:  
**VARIES**

PAGE NUMBER:  
**23**



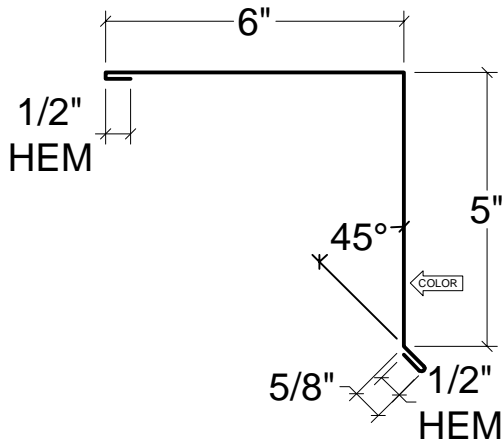

STRETCH OUT: 12 5/8"

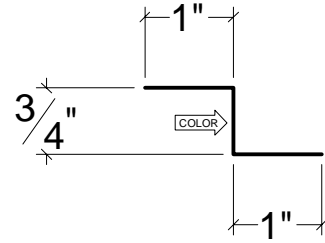

STRETCH OUT: 2 3/4"

MT-183

REVISION: 1      DATE: 04/04/13  
DESCRIPTION: RAKE TRIM (138T & 238T PANELS)

MT-184

REVISION: 0      DATE: 03/19/13  
DESCRIPTION: WAVE PANEL ZEE CLOSURE

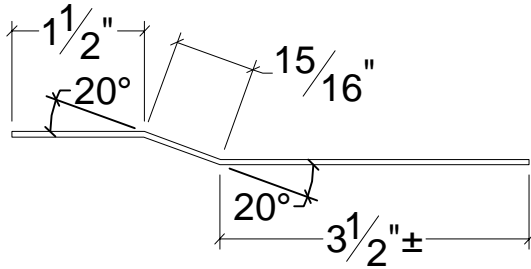

STRETCH OUT: 5 15/16"

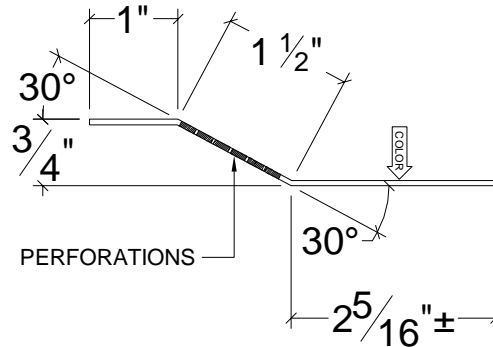

STRETCH OUT: 5 5/16"

MT-185

REVISION: 0      DATE: 01/08/14  
DESCRIPTION: 16GA GALVANIZED EAVE PLATE FOR 238T AND MAXIMA 2"

MT-186

REVISION: 1      DATE: 09/11/15  
DESCRIPTION: .063 ALUMINUM VENTED EAVE/RIDGE TRIM FOR 138T ASV

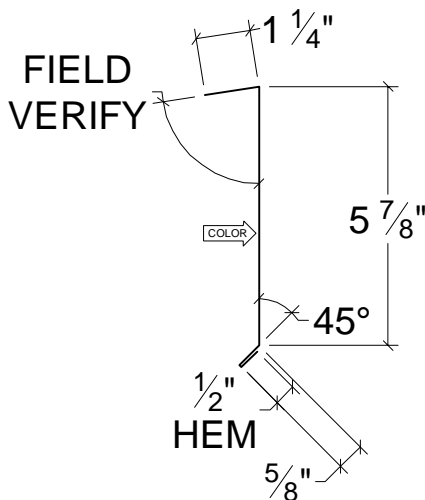

STRETCH OUT: 8 1/4"

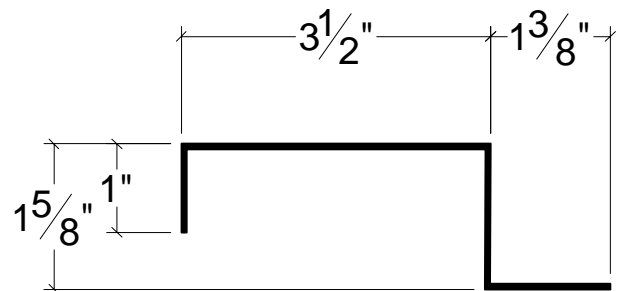

STRETCH OUT: 7 1/2"

MT-187

REVISION: 0      DATE: 01/19/16  
DESCRIPTION: 238T RETRO CLIP EAVE TRIM

MT-188

REVISION: 0      DATE: 01/19/16  
DESCRIPTION: 238T RETRO CLIP 16GA GALV. EAVE PLATE



DETAIL TYPE:

STANDARD TRIM

REVISION

10

DATE:

12/29/16

11

01/19/16

PANEL TYPE:

VARIES

PAGE NUMBER:

24

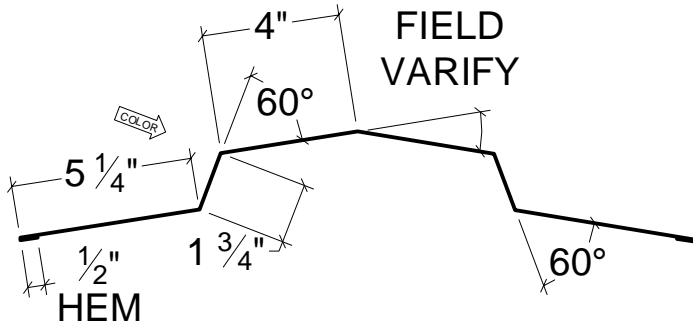

STRETCH OUT: 23"

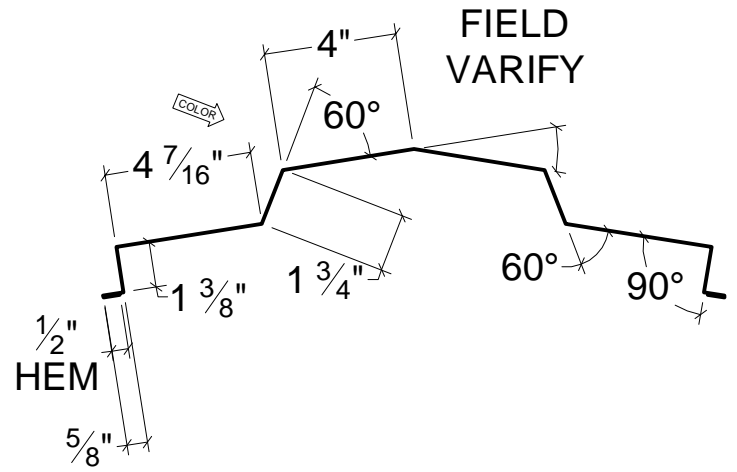

STRETCH OUT: 25 3/8"

MT-189 REVISION: 0 DATE: 01/19/16  
DESCRIPTION: FLOATING RIDGE TRIM (138T & 238T PANELS)

MT-190 REVISION: 0 DATE: 01/19/16  
DESCRIPTION: FLOATING RIDGE TRIM FOR VENTED (138T & 238T PANELS)

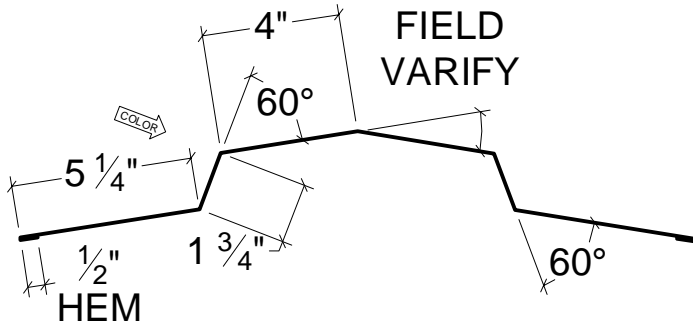

STRETCH OUT: 23"

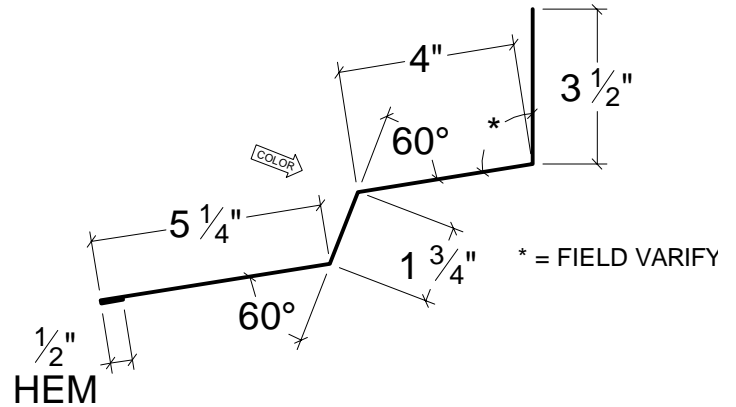

STRETCH OUT: 15"

MT-191 REVISION: 0 DATE: 01/19/16  
DESCRIPTION: FLOATING HIP TRIM (138T & 238T PANELS)

MT-192 REVISION: 0 DATE: 01/19/16  
DESCRIPTION: FLOATING HIGH SIDE TRIM (138T & 238T PANELS)

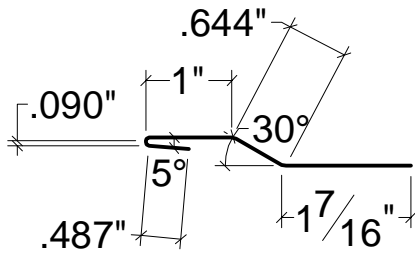

STRETCH OUT: 3 5/8"

MT-193 REVISION: 0 DATE: 04/25/16  
DESCRIPTION: WAVE CLIP



DETAIL TYPE: STANDARD TRIM

PANEL TYPE: VARIES

REVISION	DATE:
11	01/19/16
12	04/25/16

PAGE NUMBER: 25