

MIRAGE

INSTALLATION

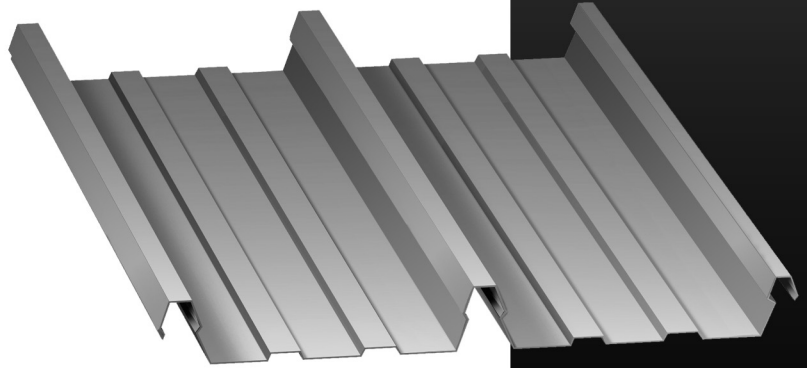



MIRAGE

MIRAGE GENERAL INFORMATION, TRIM AND ACCESSORIES



MIRAGE NOTES

♦ ♦ ♦ ♦ N O T E S ♦ ♦ ♦ ♦

The details shown on the following pages are suggestions or guidelines for installing the Mirage system. The installation details shown here are proven methods of construction, but they are not intended to cover all building requirements, designs or codes. The details may require changes or revisions due to individual project conditions.

Installation procedures shall be in accordance with the manufacturer's printed instructions, details or approved shop drawings. Installers should thoroughly familiarize themselves with all instructions prior to beginning the installation process.

The designer/installer is responsible to ensure the following:

- That the details here meet the particular building requirements.
- Awareness of and allowance for expansion / contraction of the roof panels.
- That adequate water tightness is maintained.
- That a proper uniform substructure is used to avoid panel distortion and that the substructure meets necessary code requirements.
- That all supporting members have been examined and are straight, level, and plumb.

McElroy Metal can provide all flashings and accessories shown in the installation drawings unless noted otherwise. Panels, flashing and trim shall be installed true and in proper alignment with any exposed fasteners equally spaced for the best appearance. Sealant shall be field applied on a clean, dry surface.

Some field cutting and fitting of panels and flashings is to be expected and to be considered a part of normal installation work. Workmanship shall be of the best industry standards with installation performed by experienced metal craftsmen.

Oil canning of metal panels is inherent in the product and is not a cause for rejection. Striated panels are recommended as they reduce the appearance of oil canning.

Contents of this manual are subject to change without notice. To confirm this book is the most current copy, please visit McElroy Metal's website at www.mcelroymetal.com.



MIRAGE

GENERAL INFORMATION

Mirage

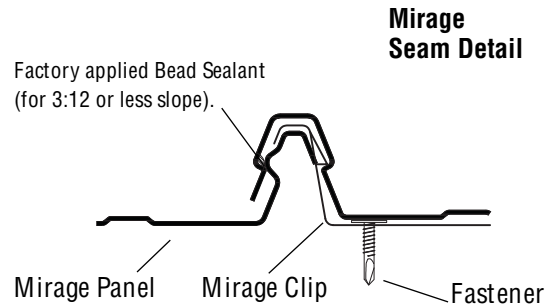
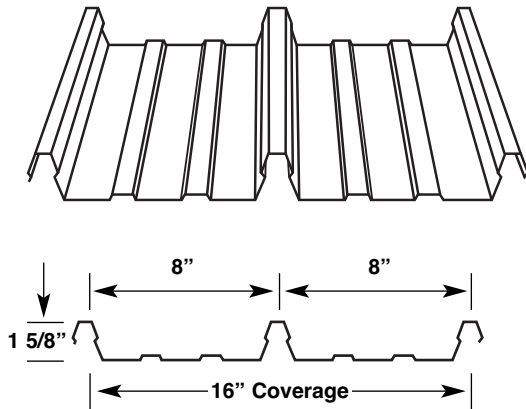

MIRAGE PANEL OPTIONS

- Panel Gauge: 24 Gauge
- Panel Width: 16"
- Panel Configurations: Ribbed
- Standard Panel Length: Up to 40'
- Minimum Slope: 1/4:12
Factory applied sealant is required in seam (side laps) at less than 3:12 slope.
- Substrate: Galvalume Plus
- Paint System: Kynar 500®

Please refer to www.mcelroymetal.com or contact a McElroy Representative for more specific information regarding Mirage.

Testing Data:

- Class A - Fire Rating.
- UL580 Class90 - Uplift Test.
- ASTM E1592 - Uplift Test.
- UL2218 - Class 4 Impact Resistance.
- ASTM E1646 - Water Infiltration.
- ASTM E1680 - Air Infiltration.
- Florida State Approval

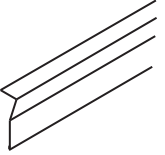
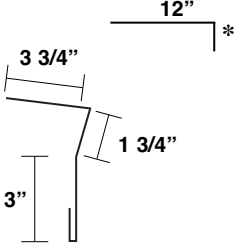
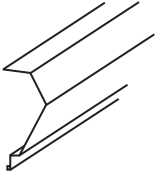
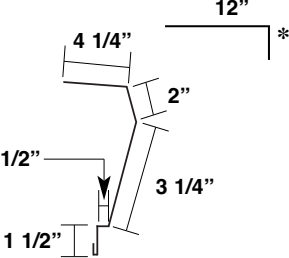
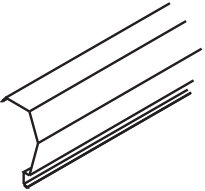
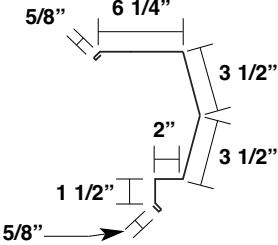
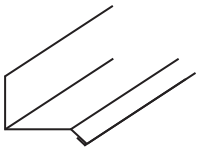
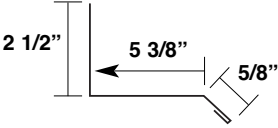
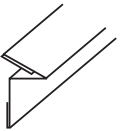
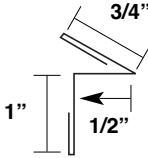
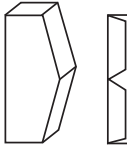
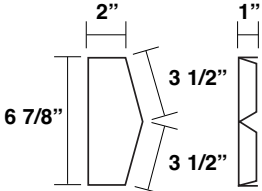
	<p>Material: 24 Ga. Length: 10' 3" 20' 3"</p>	
<p>Simple Eave* *specify roof pitch</p>		
	<p>Material: 24 Ga. Length: 10' 3" 20' 3"</p>	
<p>Sculptured Eave* *specify roof pitch</p>		
	<p>Material: 24 Ga. Length: 10' 3" 20' 3"</p>	
<p>Rake Trim</p>		
	<p>Material: 24 Ga. Length: 10' 3" 20' 3"</p>	
<p>Rake Tie-In</p>		
	<p>Material: 24 Ga. Length: 10' 3" 20' 3"</p>	
<p>Rake Slide</p>		
	<p>Material: 24 Ga. Length: N/A</p>	
<p>Rake Closure</p>		

MIRAGE TRIM



	<p>Material: 24 Ga. Length: 10' 3" 20' 3"</p>	<p>Zee Closure</p>
	<p>Material: 24 Ga. Length: 10' 3" 20' 3"</p>	<p>High Side Tie-In Trim* Up to 6:12 Pitch *specify roof pitch</p>
	<p>Material: 24 Ga. Length: 10' 3" 20' 3"</p>	<p>Alternate High Side Tie-In Trim* Up to 6:12 Pitch *specify roof pitch</p>
	<p>Material: 24 Ga. Length: 10' 3" 20' 3"</p>	<p>High Side Eave Flashing* *specify roof pitch</p>
	<p>Material: 24 Ga. Length: 10' 3" 20' 3"</p>	<p>Alternate High Side Eave Flashing* *specify roof pitch</p>
	<p>Material: 24 Ga. Length: 10' 3" 20' 3"</p>	<p>Fixed Ridge Cap* Up to 6:12 Pitch *specify roof pitch</p>

	<p>Material: 24 Ga. Length: 10' 3" 20' 3"</p>	
<p>Alternate Fixed Ridge Cap* Up to 6:12 Pitch *specify roof pitch</p>		
	<p>Material: 24 Ga. Length: 10' 3" 20' 3"</p>	
<p>Floating Ridge Cap* Up to 6:12 Pitch *specify roof pitch</p>		
	<p>Material: 24 Ga. Length: 10' 3" 20' 3"</p>	
<p>Alternate Floating Ridge Cap* Up to 6:12 Pitch *specify roof pitch</p>		
	<p>Material: 24 Ga. Length: 1' 8"</p>	
<p>Fixed Peak Box For 1:12</p>		
	<p>Material: 24 Ga. Length: 1' 8"</p>	
<p>Fixed Peak Box For 2:12</p>		
	<p>Material: 24 Ga. Length: 1' 8"</p>	
<p>Fixed Peak Box For 3:12</p>		

MIRAGE TRIM



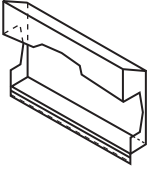
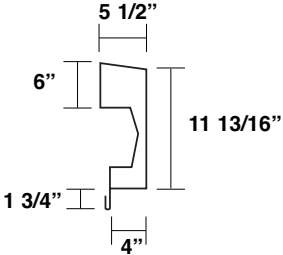
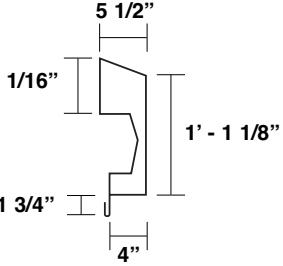
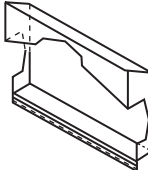
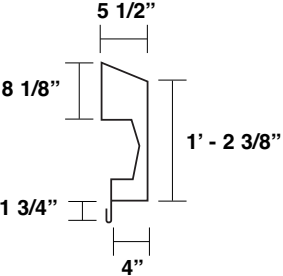
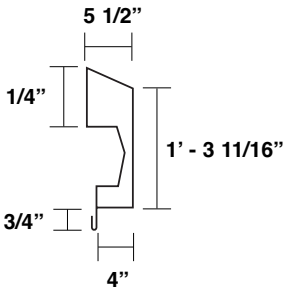
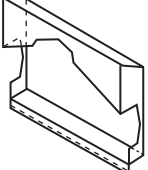
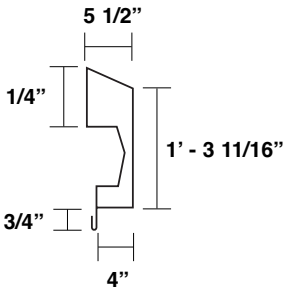
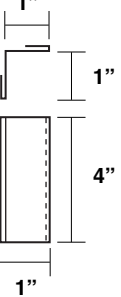
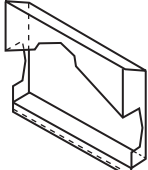
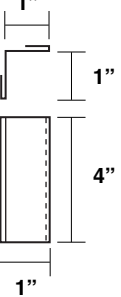
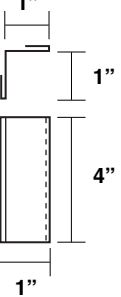

	<p>Material: 24 Ga. Length: 1' 8"</p>	
	<p>Material: 24 Ga. Length: 1' 8"</p>	
	<p>Material: 24 Ga. Length: 1' 8"</p>	
	<p>Material: 24 Ga. Length: 2' 1"</p>	
	<p>Material: 24 Ga. Length: 2' 1"</p>	

	<p>Material: 24 Ga. Length: 2' 1"</p>	
<p>Floating Peak Box For 3:12</p>	<p>Material: 24 Ga. Length: 2' 1"</p>	
	<p>Material: 24 Ga. Length: 2' 1"</p>	
<p>Floating Peak Box For 4:12</p>	<p>Material: 24 Ga. Length: 2' 1"</p>	
	<p>Material: 24 Ga. Length: 2' 1"</p>	
<p>Floating Peak Box For 5:12</p>	<p>Material: 24 Ga. Length: 2' 1"</p>	
	<p>Material: 24 Ga. Length: 0' 4"</p>	
<p>Floating Peak Box For 6:12</p>	<p>Material: 24 Ga. Length: 0' 4"</p>	
<p>Cinch Angle</p>		

MIRAGE TRIM

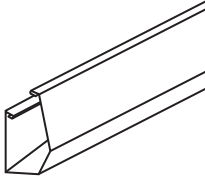
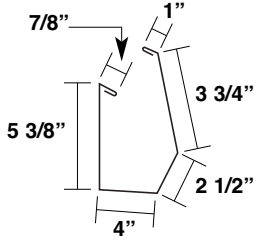
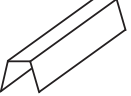
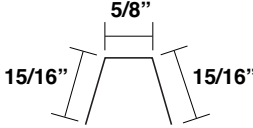
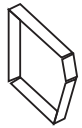
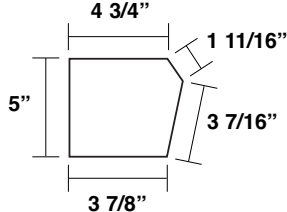
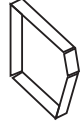
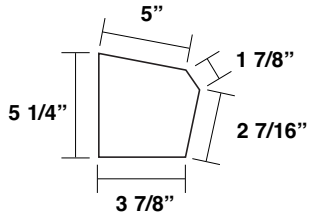

	<p>Material: 24 Ga. Length: N/A</p> <p>**Snow guards required to prevent damage caused by sliding snow.</p>	<p>**Outside Corner Box Up To 3:12</p>
	<p>Material: 24 Ga. Length: N/A</p> <p>**Snow guards required to prevent damage caused by sliding snow.</p>	<p>**Sculptured Corner Box</p>
	<p>Material: 24 Ga. Length: N/A</p> <p>**Snow guards required to prevent damage caused by sliding snow.</p>	<p>**High Side Corner Box</p>
	<p>Material: 24 Ga. Length: N/A</p> <p>**Snow guards required to prevent damage caused by sliding snow.</p>	<p>**Gutter Corner Box Above 3:12 to 6:12</p>
	<p>Material: 24 Ga. Length: 10' 3" 20' 3"</p> <p>**Snow guards required to prevent damage caused by sliding snow.</p>	<p>**Gutter Up To 3:12</p>

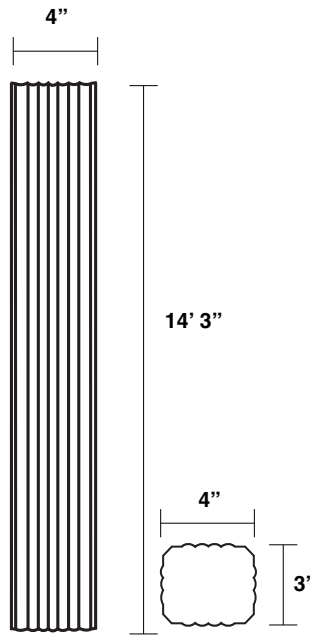
	<p>Material: 24 Ga. Length: 10' 3" 20' 3"</p> <p>**Snow guards required to prevent damage caused by sliding snow.</p>	
<p>**Gutter Above 3:12 to 6:12</p>		
	<p>Material: 24 Ga. Length: 0' 6"</p>	
<p>Gutter Strap</p>		
	<p>Material: 24 Ga. Length: N/A</p>	
<p>Gutter End Cap Up To 3:12</p>		
	<p>Material: 24 Ga. Length: N/A</p>	
<p>Gutter End Cap Above 3:12 to 6:12</p>		
	<p>Material: 26 Ga. Length: 14' 3"</p>	
<p>3" x 4" Downspout</p>		









MIRAGE TRIM

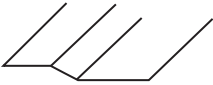
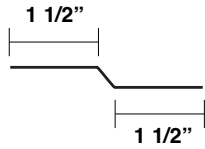

	<p>Material: 24 Ga. Length: N/A</p>	<p>Aluminum Downspout Outlet Box</p>
	<p>Material: 26 Ga. Length: 10"</p>	<p>Downspout Strap</p>
	<p>Material: 26 Ga. Length: N/A</p>	<p>3" X 4" Downspout Elbow</p>

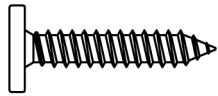

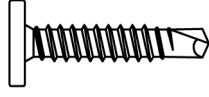

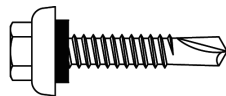
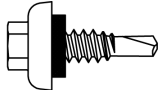
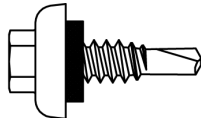
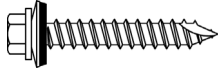
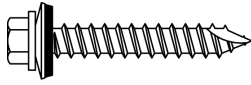
Notes:

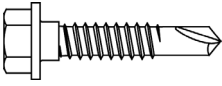
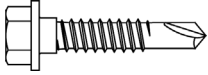
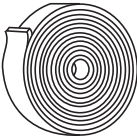
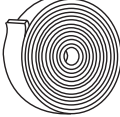
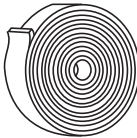
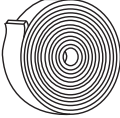
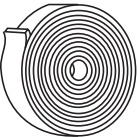
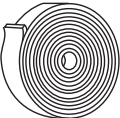

Blank area for notes.

 Utility Eave Plate Item #: 38680	Material: 16 Ga. Length: 10' 0"	
 Mirage Clip Item #: 38620	Material: N/A Length: N/A	
 #10 - 12 x 1" Type A Pancake Head Woodgrip Item #: 36116	Material: N/A Length: 1"	
 #10 - 16 x 1" TEK2 Pancake Head Self-Driller Item #: 36117	Material: N/A Length: 1"	
 1/4 - 14 x 1 1/4" TEK2 ZAC Self-Driller (Part # Varies by Color)	Material: N/A Length: 1 1/4"	
 1/4 - 14 x 7/8" LAPTEK ZAC Self-Driller (Part # Varies by Color)	Material: N/A Length: 7/8"	
 #14 x 1 1/2" Type AB ZAC (Part # Varies by Color)	Material: N/A Length: 1 1/2"	

MIRAGE ACCESSORIES

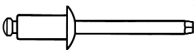
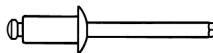

	<p>Material: N/A Length: 1 1/4"</p>	 <p>1/4 - 14 x 1-1/4" Shoulder TEK2 3/8 HWH WO/W Item #: 10975</p>
	<p>Material: N/A Length: 20'</p>	 <p>Bead Tape Sealant 1/4" x 5/16" x 20' Item#: 95462</p>
	<p>Material: N/A Length: 45'</p>	 <p>Roll Tape Sealant 3/8" x 3/32" x 45' Item#: 95340</p>
	<p>Material: N/A Length: 30'</p>	 <p>Roll Tape Sealant 1/8" x 1" x 30' Item #: 95345</p>
	<p>Material: N/A Length: N/A</p>	 <p>White Urethane Sealant Item #: 95320</p>
	<p>Material: N/A Length: N/A</p>	 <p>Butyl Tube Sealant Item #: 95342</p>
	<p>Material: N/A Length: 1/8"</p>	 <p>43D Pop Rivets (Part # Varies by Color)</p>

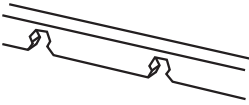
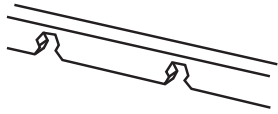
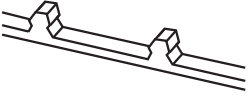
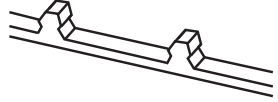
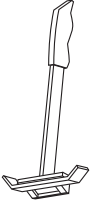
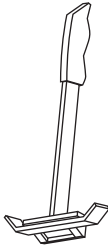
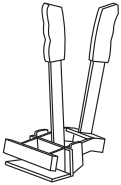
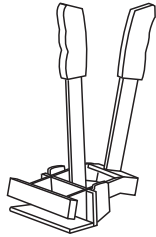
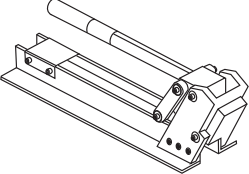
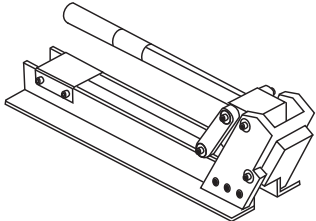
	<p>Material: N/A Length: N/A</p>	
<p>Touch-Up Paint Pen (Part # Varies by Color)</p>		
	<p>Material: N/A Length: 2' 8"</p>	
<p>Outside Closure Item #: 38622</p>		
	<p>Material: N/A Length: 2' 8"</p>	
<p>Inside Closure Item #: 38621</p>		
	<p>Material: N/A Length: N/A</p>	
<p>Mirage Hem Down Tool Item #: 38618</p>		
	<p>Material: N/A Length: N/A</p>	
<p>Mirage and Mirage II Hem Up Tool Item #: 38617</p>		
	<p>Material: N/A Length: N/A</p>	
<p>Mirage and Mirage II Notching Tool Item #: 38619</p>		

MIRAGE INSTALLATION ILLUSTRATIONS

COMPRESSIBLE BLANKET
INSULATION NOT
SHOWN FOR CLARITY

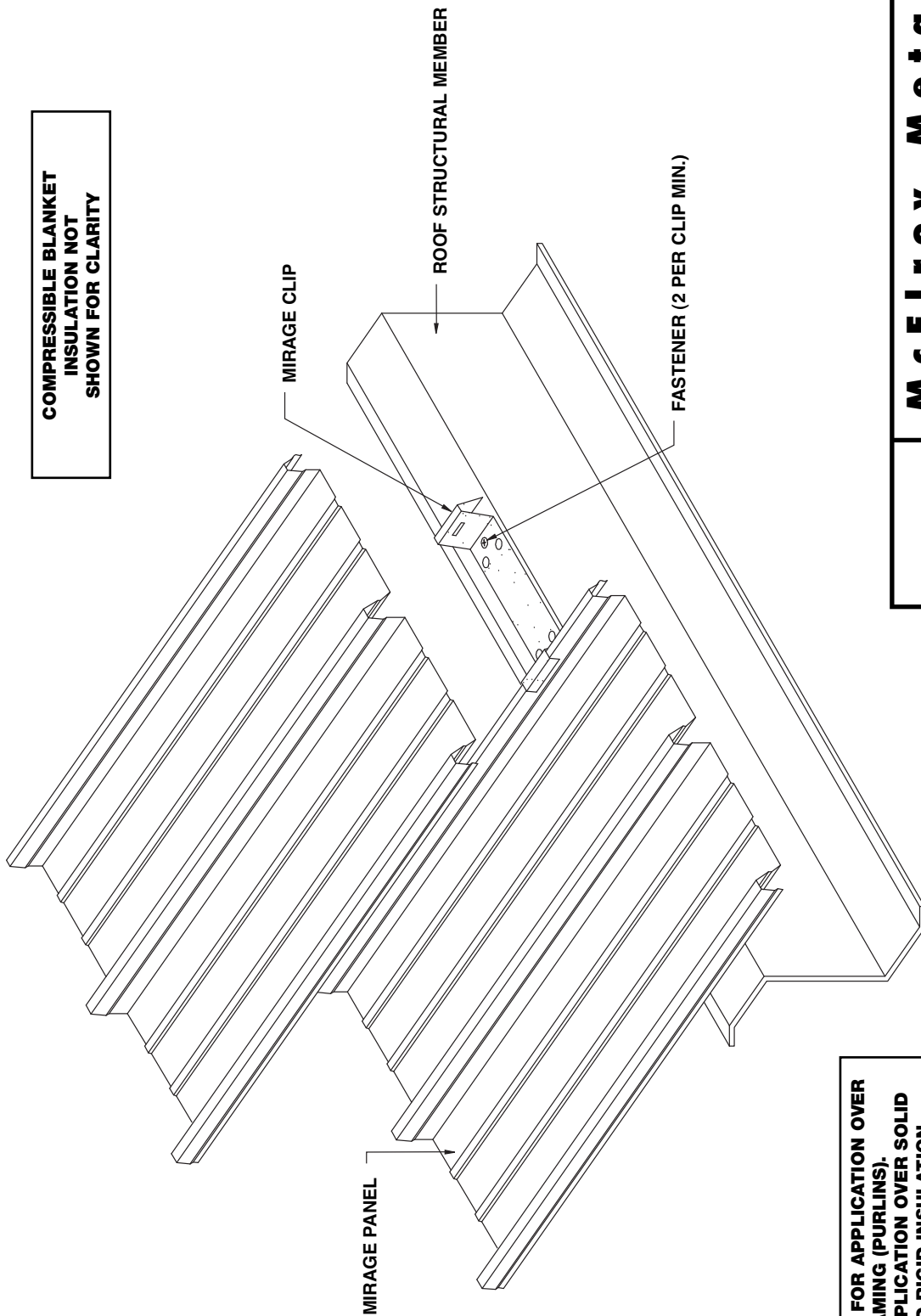

DETAIL SHOWN IS FOR APPLICATION OVER
OPEN FRAMING (PURLINS).
DETAILS FOR APPLICATION OVER SOLID
DECKING AND RIGID INSULATION
ARE SIMILAR.



M c E l r o y M e t a l

Mirage
SIDE LAP

Technical Service: 1-800-950-9082

***REQUIRED AT
LESS THAN 3:12**

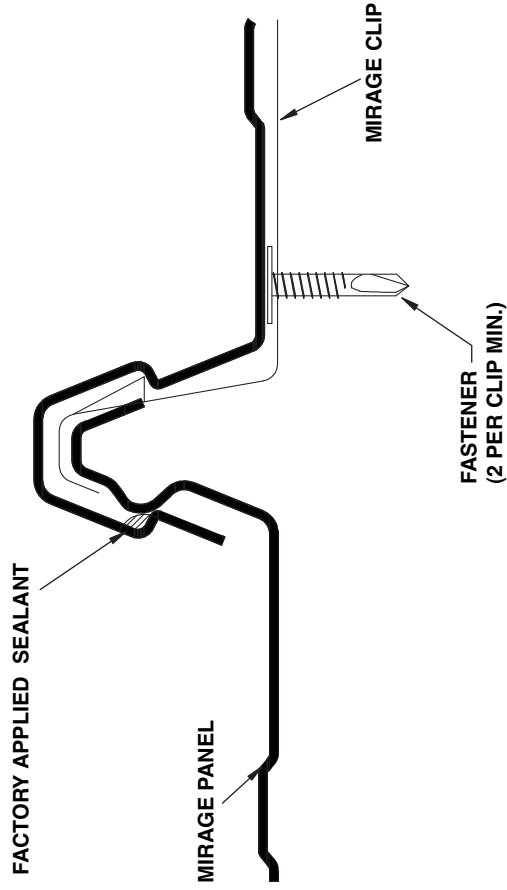

NOTES

1. Cut a 4" long strip from 1" Roll Tape Sealant and place on panel at each clip location.
2. Install Panel Clips.
3. Place continuous run of Bead Tape Sealant full length of panel.
4. Install next panel. Some resistance should be expected, and a rubber mallet may be used to snap panel into place.

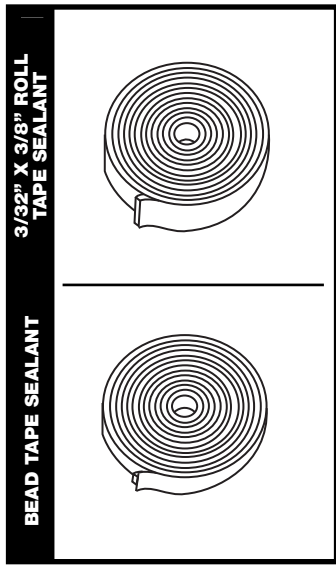

BEAD TAPE SEALANT

**3/32" X 3/8" ROLL
TAPE SEALANT**

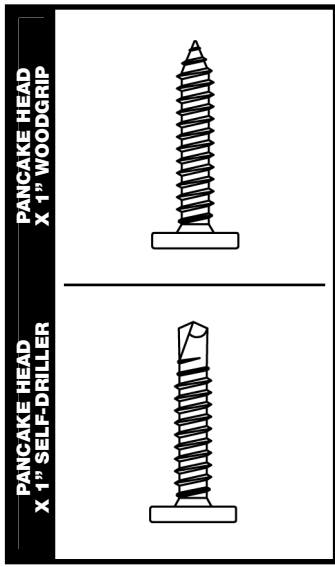

**PANCAKE HEAD
X 1" SELF-DRILLER**

**PANCAKE HEAD
X 1" WOODGRIP**

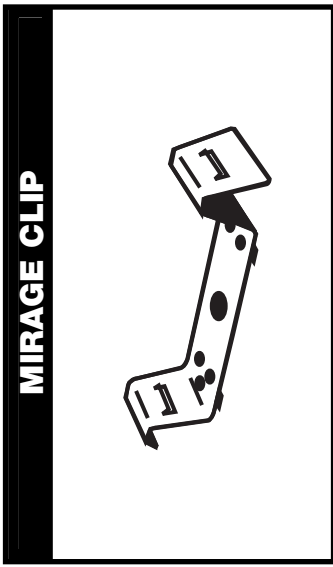

MIRAGE CLIP



McElroy Metal

**Mirage
SIDE LAP DETAIL**

Technical Service: 1-800-950-9082

COMPRESSIBLE BLANKET
INSULATION NOT
SHOWN FOR CLARITY

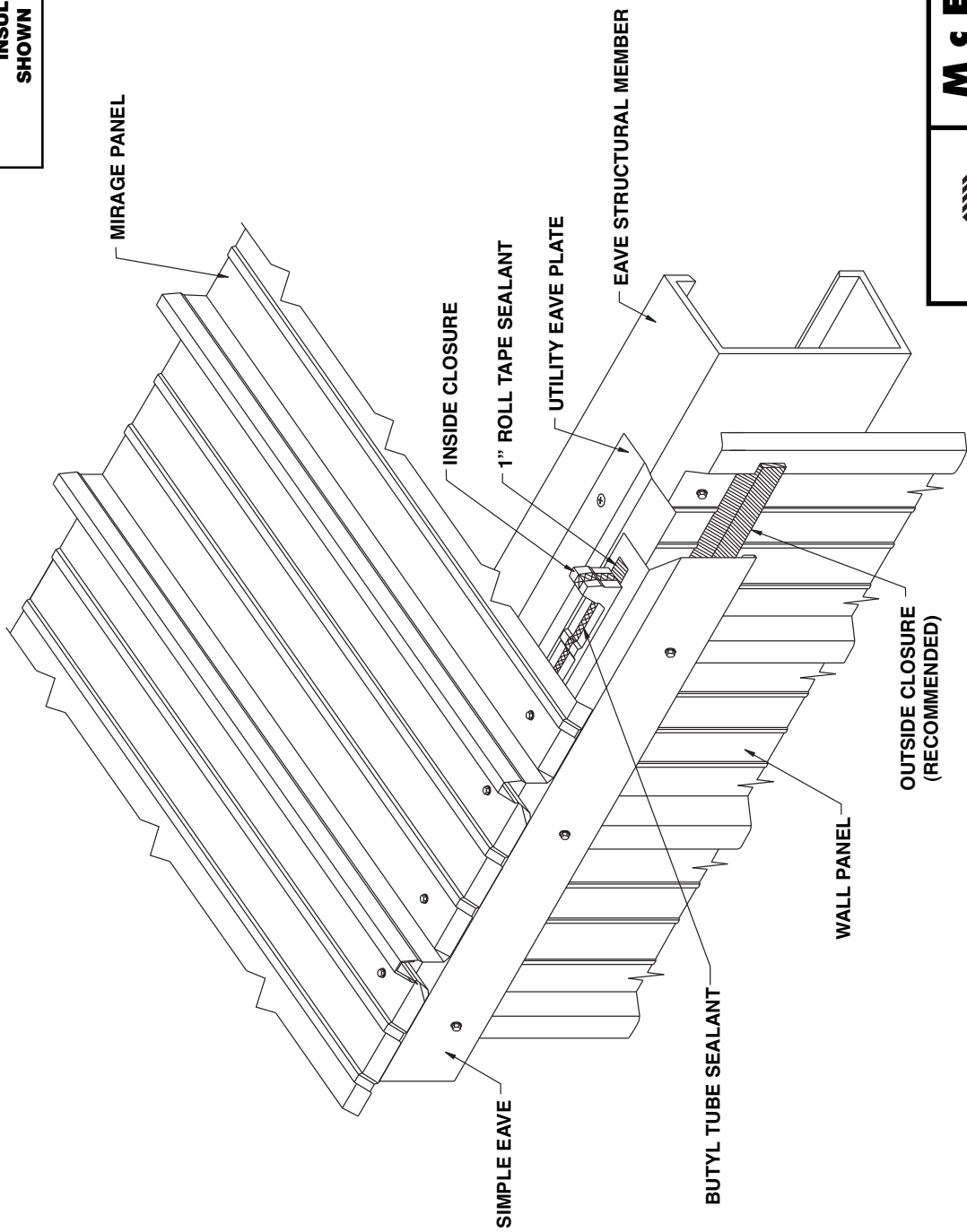

M c E l r o y M e t a l

**Mirage
EAVE TRIM**

Technical Service: 1-800-950-9082

UTILITY EAVE PLATE

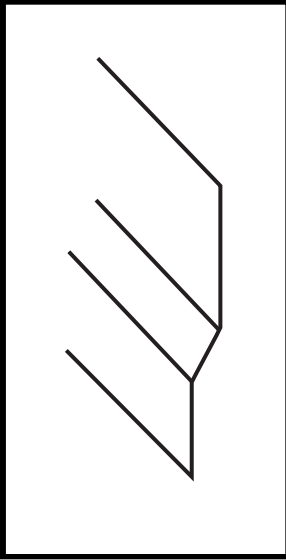

SIMPLE EAVE TRIM

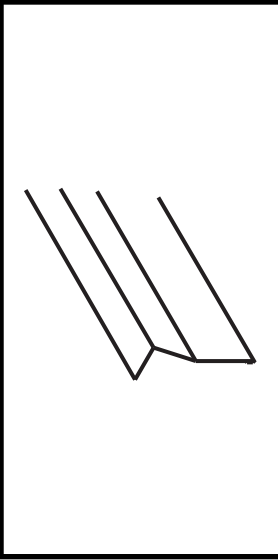

INSIDE CLOSURE

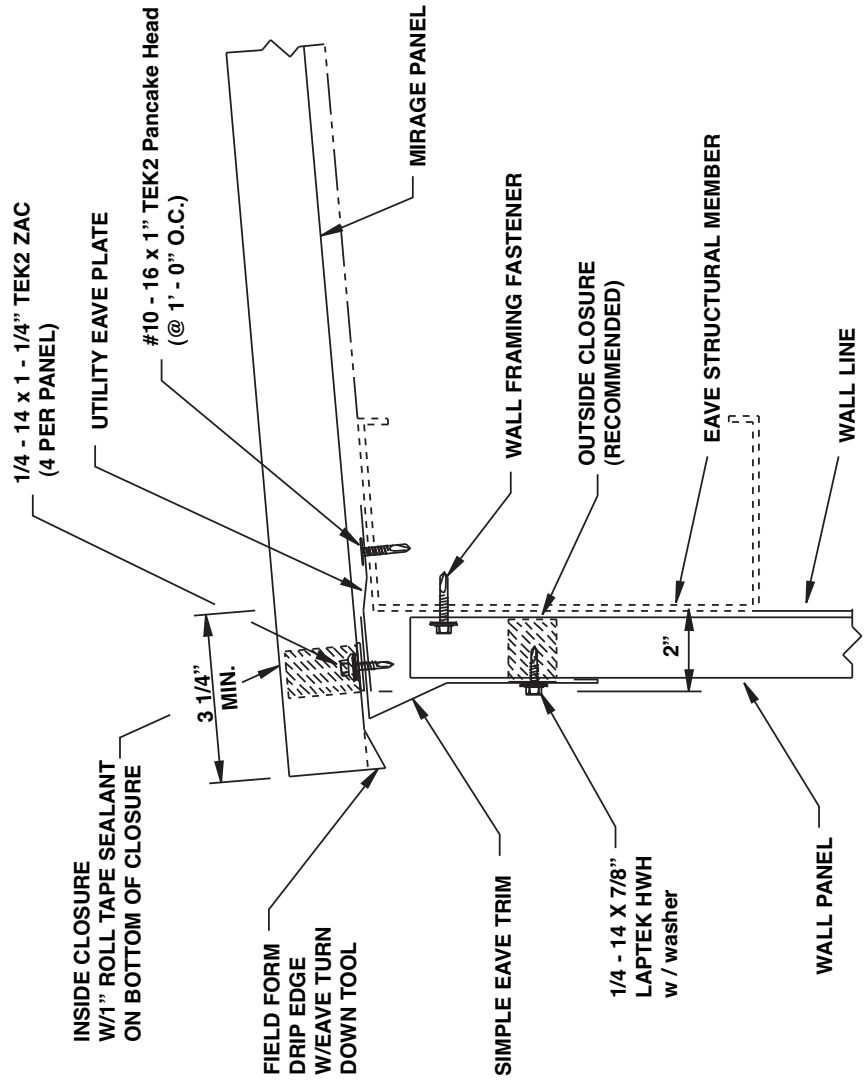
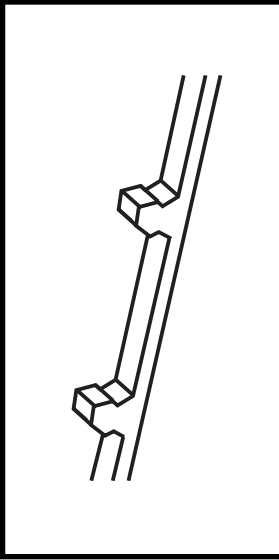

NOTES

1. Attach Utility Eave Plate with face edge 2" outside of building wall line using #10 - 16 x 1" TEK2 Pancake Head at 1' - 0" O.C. to eave strut.
2. Attach Eave Trim to Utility Eave Plate with #10 - 16 x 1" TEK2 Pancake Head at 4' - 0" O.C. and to wall panel with 1/4 - 14 x 7/8" LAPTEK HWH w/washer at major ribs.
3. Place Inside Closure with continuous run of Roll Tape Sealant on bottom and Butyl Tube Sealant on top of closure.
4. Attach roof panel to Utility Eave Plate with 1/4 - 14 x 1 - 1/4" TEK2 ZAC. Fasteners must penetrate sealant.
5. Field form Drip Edge on end of panel.



M c E l r o y M e t a l

**Mirage
EAVE TRIM DETAIL**

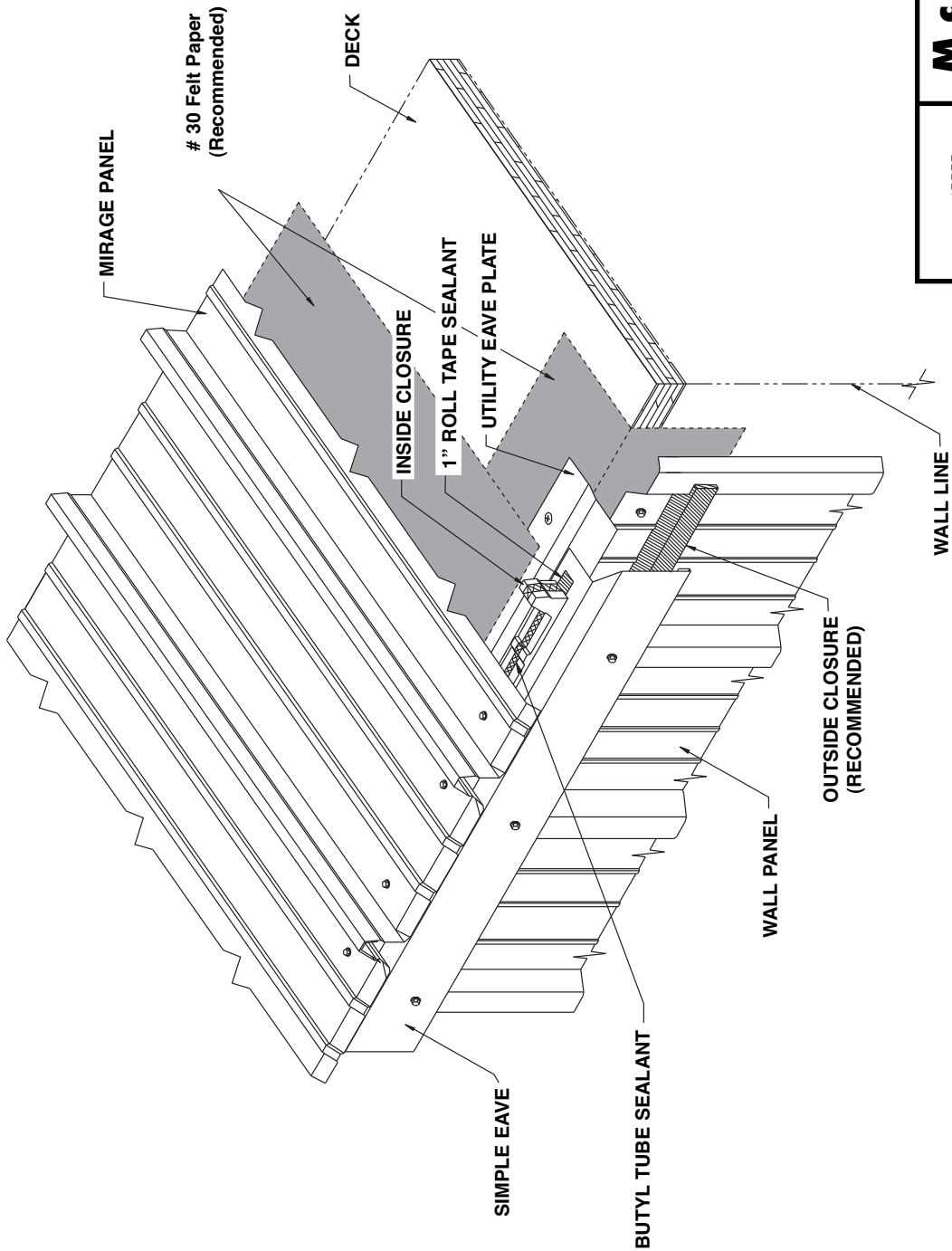

M c E I r o y M e t a l

**Mirage
EAVE TRIM W/DECK**

Technical Service: 1-800-950-9082

UTILITY EAVE PLATE

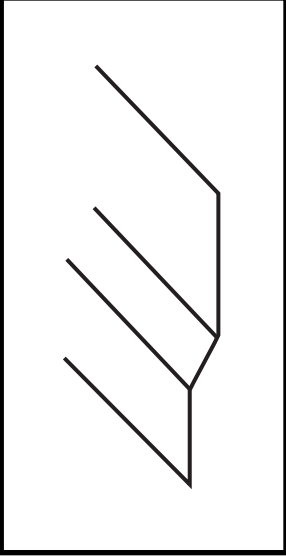

SIMPLE EAVE TRIM

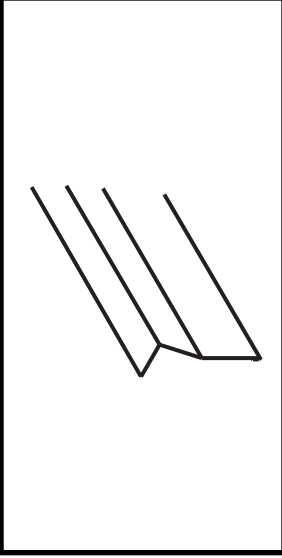

INSIDE CLOSURE

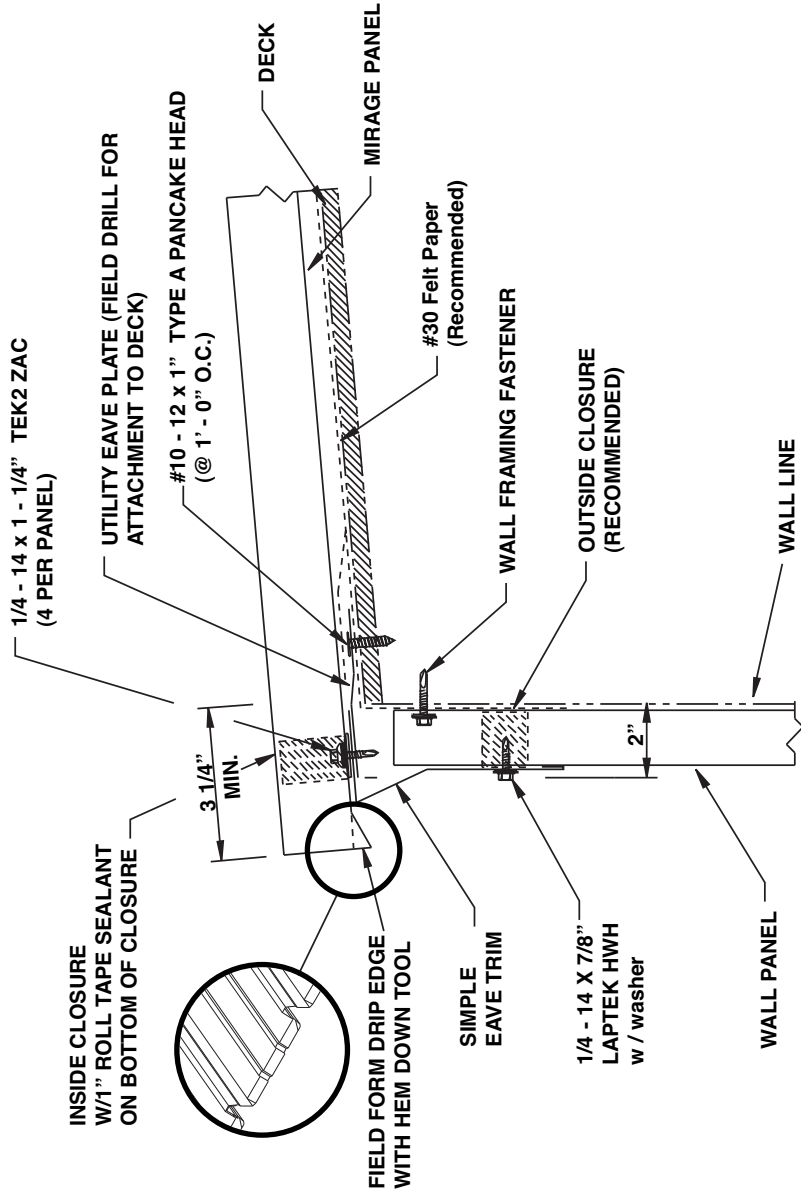
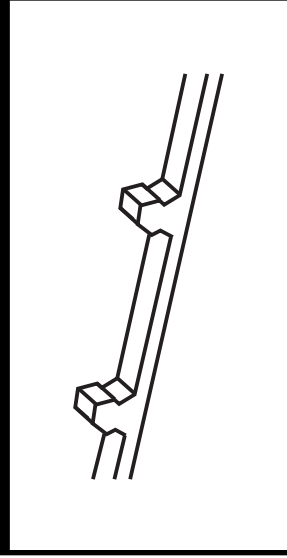

NOTES

1. Attach Utility Eave Plate with face edge 2" outside of building wall line. Field drill Utility Eave Plate for #10 - 12 x 1" TYPE A Pancake Head at 1' - 0" O.C.
2. Attach Eave Trim to Utility Eave Plate with #10 - 16 x 1" TEK2 Pancake Head at 4' - 0" O.C. and to wall panel with 1/4 - 14 X 7/8" LAPTEK HWH w / washer at major ribs.
3. Place Inside Closure with continuous run of Roll Tape Sealant on bottom and Butyl Tube Sealant on top of closure.
4. Attach Roof Panel to Utility Eave Plate with 1/4 - 14 x 1 - 1/4" TEK2 ZAC. Fastener must penetrate sealant.
5. Field form Drip Edge on end of panel.



M c E l r o y M e t a l
 Mirage
 EAVE TRIM W/DECK DETAIL

COMPRESSIBLE BLANKET
INSULATION NOT
SHOWN FOR CLARITY

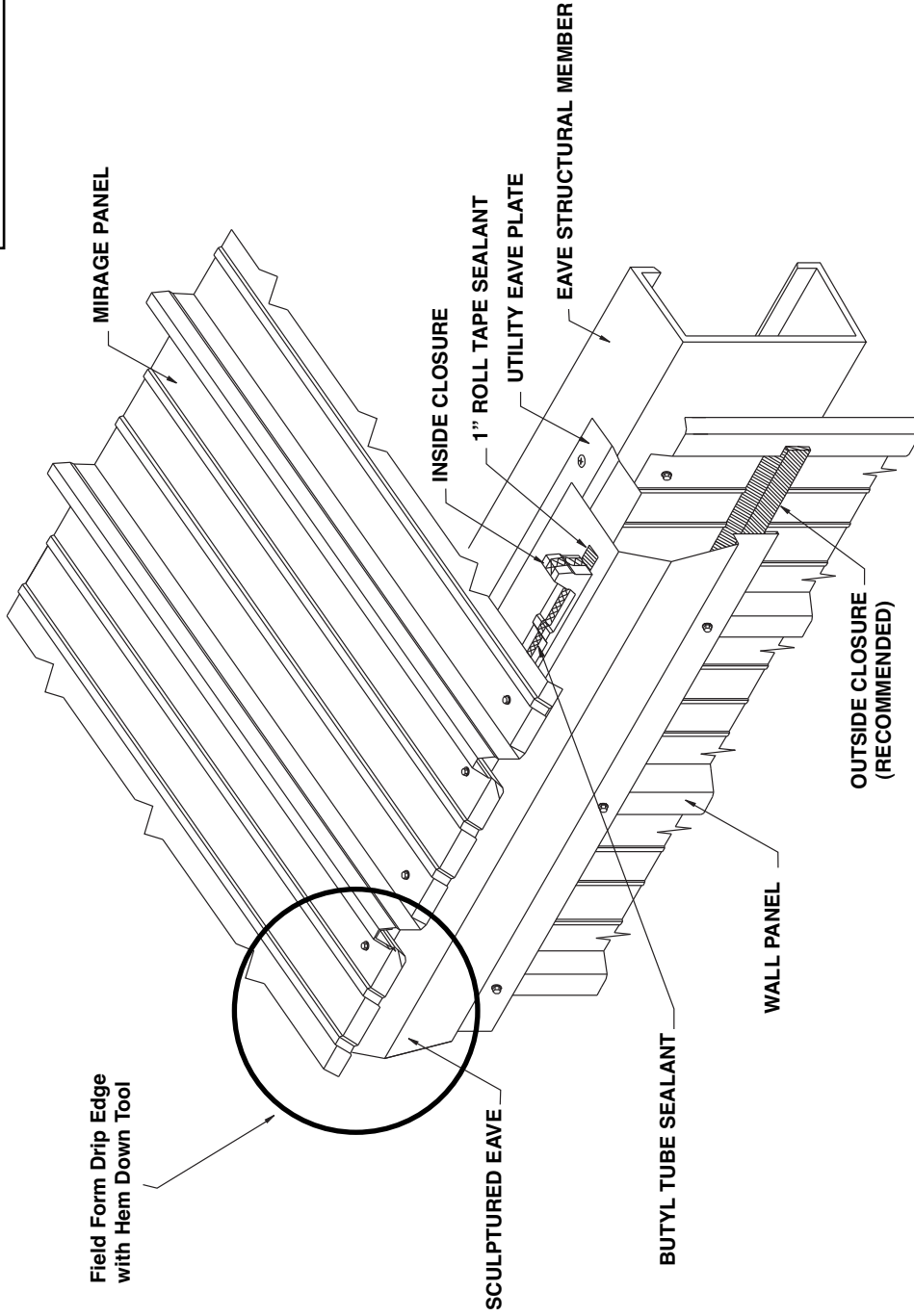

McElroy Metal

Mirage

SCULPTURED EAVE TRIM

Technical Service: 1-800-950-9082

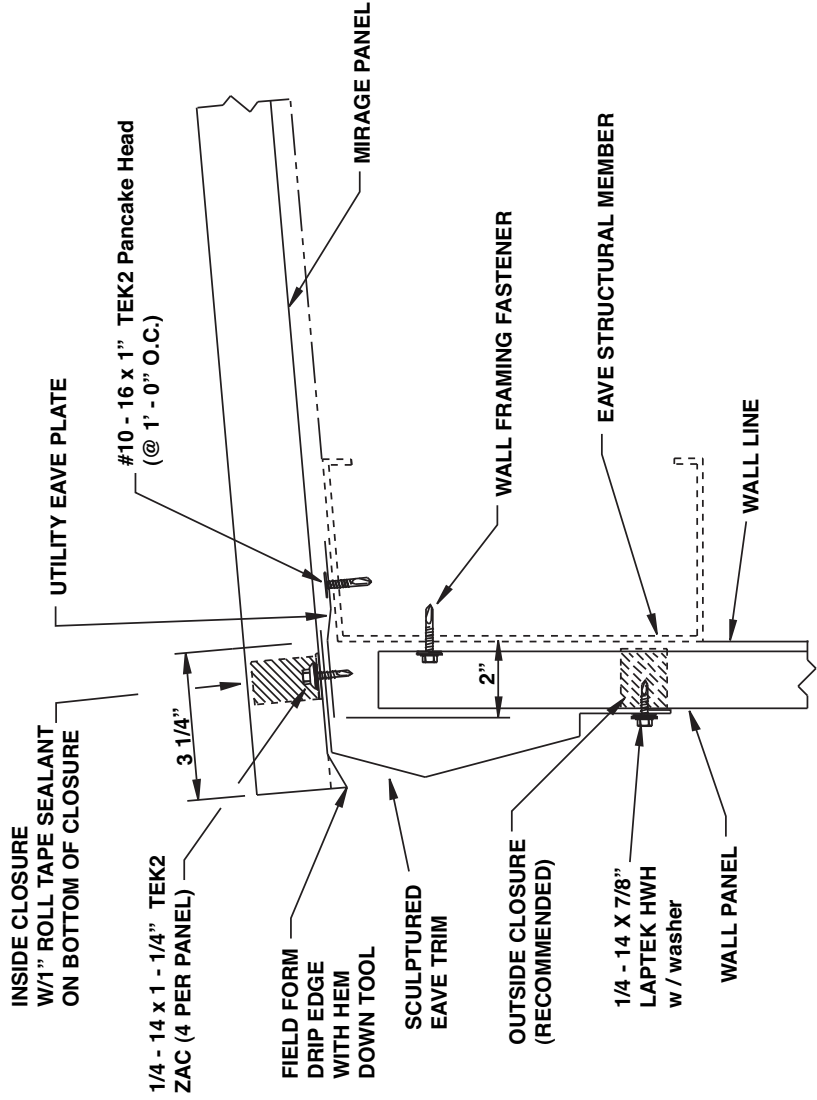

- NOTES**
1. Attach Utility Eave Plate with face edge 2" outside of building wall line using #10 - 16 x 1" TEK2 Pancake Head at 1' - 0" O.C. to Eave Strut.
 2. Attach Sculptured Eave Trim to Utility Eave Plate with #10 - 16 x 1" TEK2 Pancake Head at 4' - 0" O.C. and to wall panel with 1/4 - 14 X 7/8" LAPTEK HWH w / washer at major ribs.
 3. Place Inside Closure with continuous run of Roll Tape Sealant on bottom and Butyl Tube Sealant on top of closure.
 4. Attach Roof Panel to Utility Eave Plate with 1/4 - 14 x 1 - 1/4" TEK2 ZAC. Fasteners must penetrate sealant.
 5. Field form Drip Edge on end of panel.

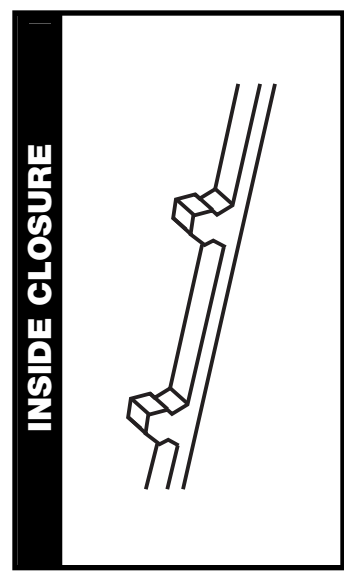
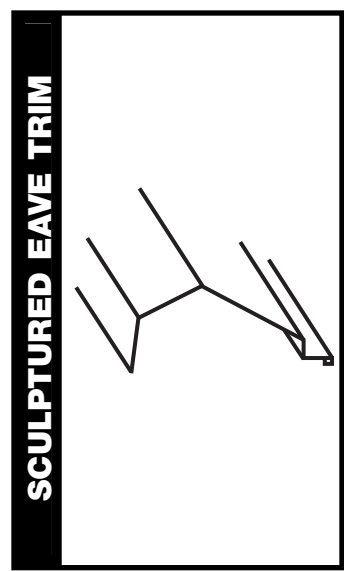
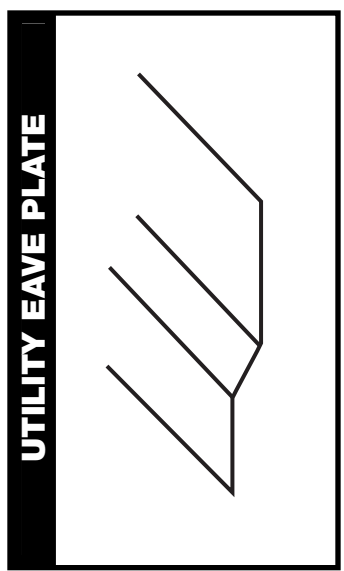



M c E l r o y M e t a l

Mirage
SCULPTURED EAVE TRIM
DETAIL

Technical Service: 1-800-950-9082

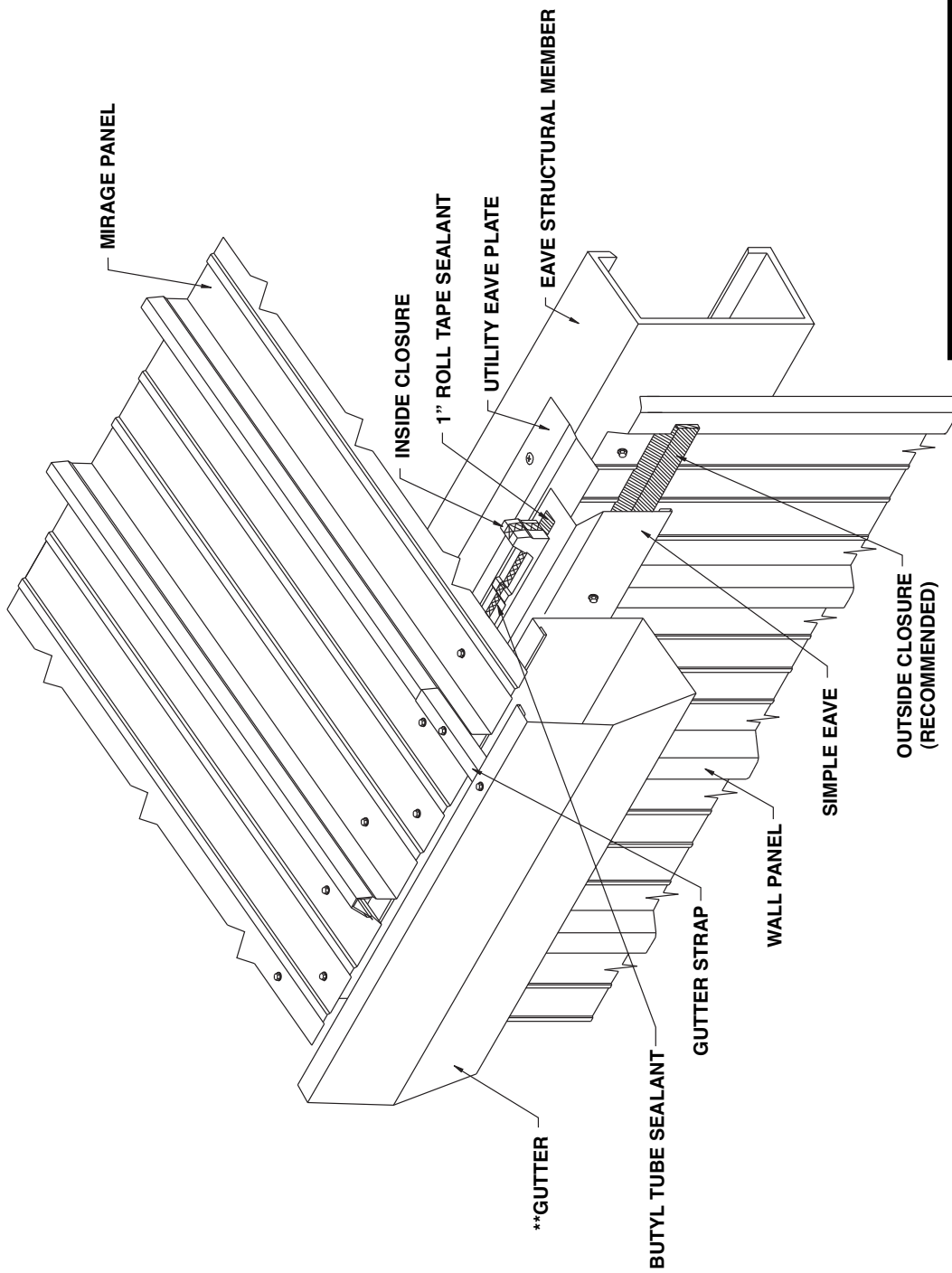

**Snow guards required to prevent damage caused by sliding snow.



M c E l r o y M e t a l

Mirage
GUTTER TRIM UP TO 3:12

Technical Service: 1-800-950-9082

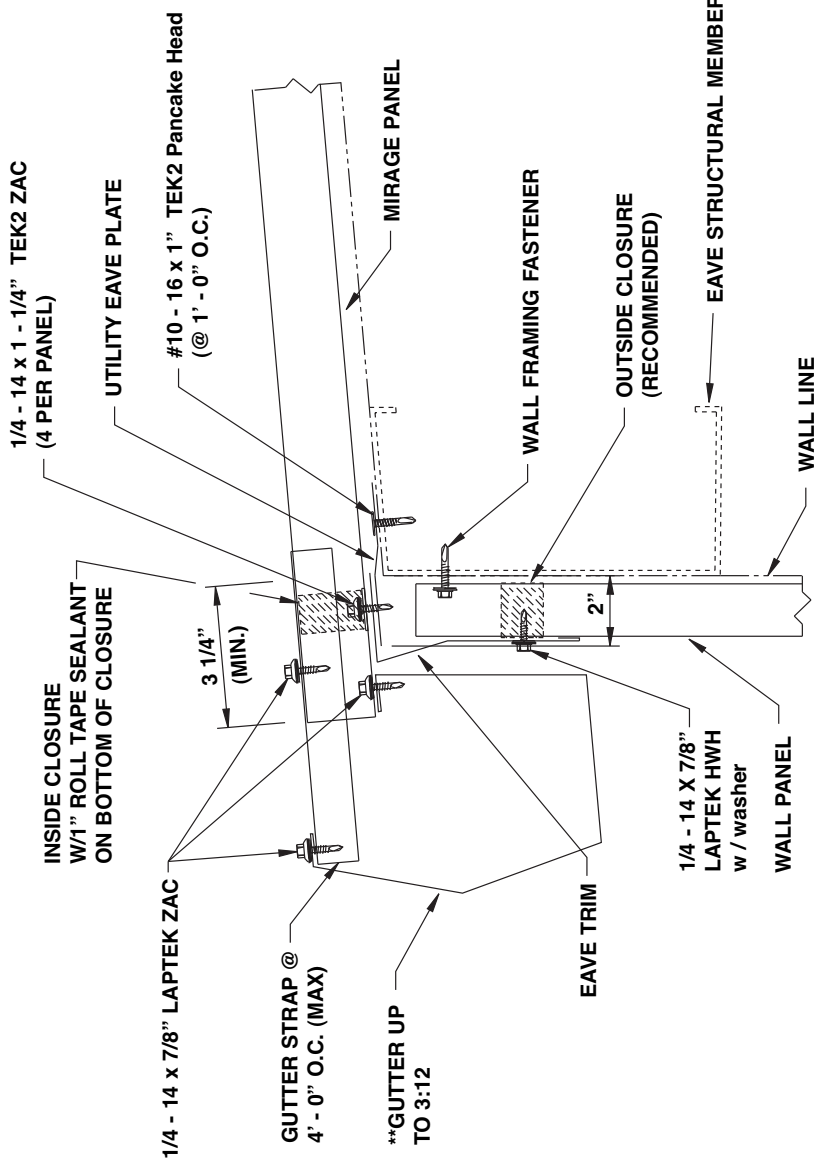

NOTES

1. Attach Utility Eave Plate with face edge 2" outside of building wall line using #10 - 16 x 1" TEK2 Pancake Head at 1' - 0" O.C. to Eave Strut.
2. Attach Eave Trim to Utility Eave Plate with #10 - 16 x 1" TEK2 Pancake Head at 4' - 0" O.C. and to wall panel with 1/4 - 14 X 7/8" LAPTEK HWH w / washer at major ribs.
3. Place Inside Closure with continuous run of Roll Tape Sealant on bottom and Butyl Tube Sealant on top of closure.
4. Attach roof panel to Utility Eave Plate with 1/4 - 14 x 1 - 1/4" TEK2 ZAC. Fasteners must penetrate sealant.
5. Attach Gutter Strap to Roof Panel with 1/4 - 14 x 7/8" LAPTEK ZAC. Straps spaced at 4' - 0" (Max.)
6. Attach Gutter to Roof Panel with 1/4 - 14 x 7/8" LAPTEK ZAC at 8" O.C. and to Gutter with 1/4 - 14 x 7/8" LAPTEK ZAC.

**Snow guards required to prevent damage caused by sliding snow.

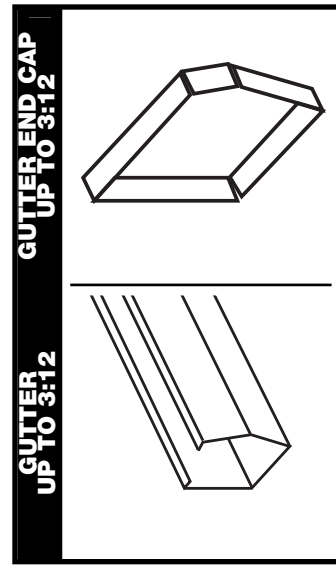
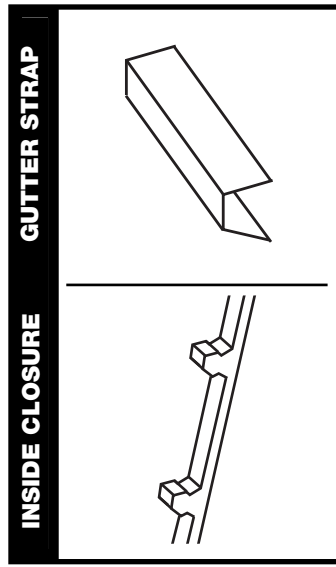
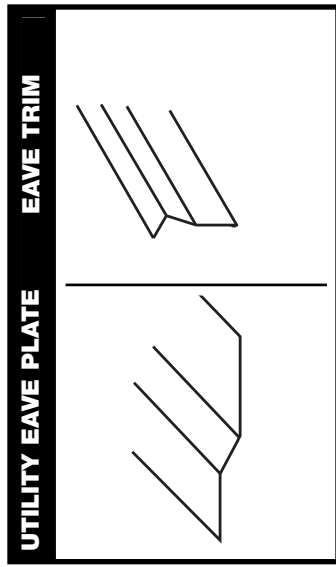

M c E l r o y M e t a l

**Mirage
GUTTER TRIM UP TO 3:12
DETAIL**

Technical Service: 1-800-950-9082

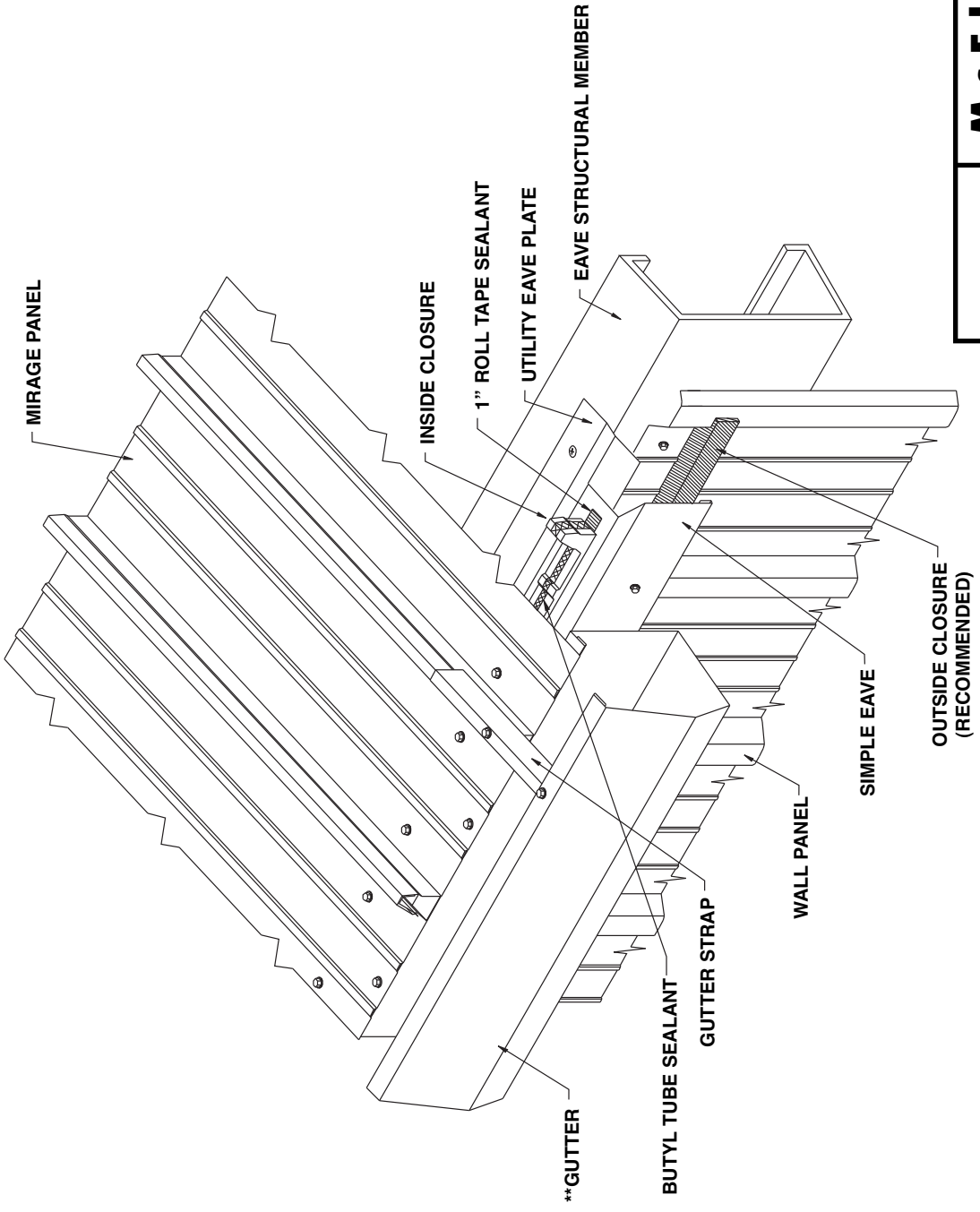

**Snow guards required to prevent damage caused by sliding snow.

	M c E l r o y M e t a l
Mirage TRIM OVER 3:12 TO 6:12	
Technical Service: 1-800-950-9082	

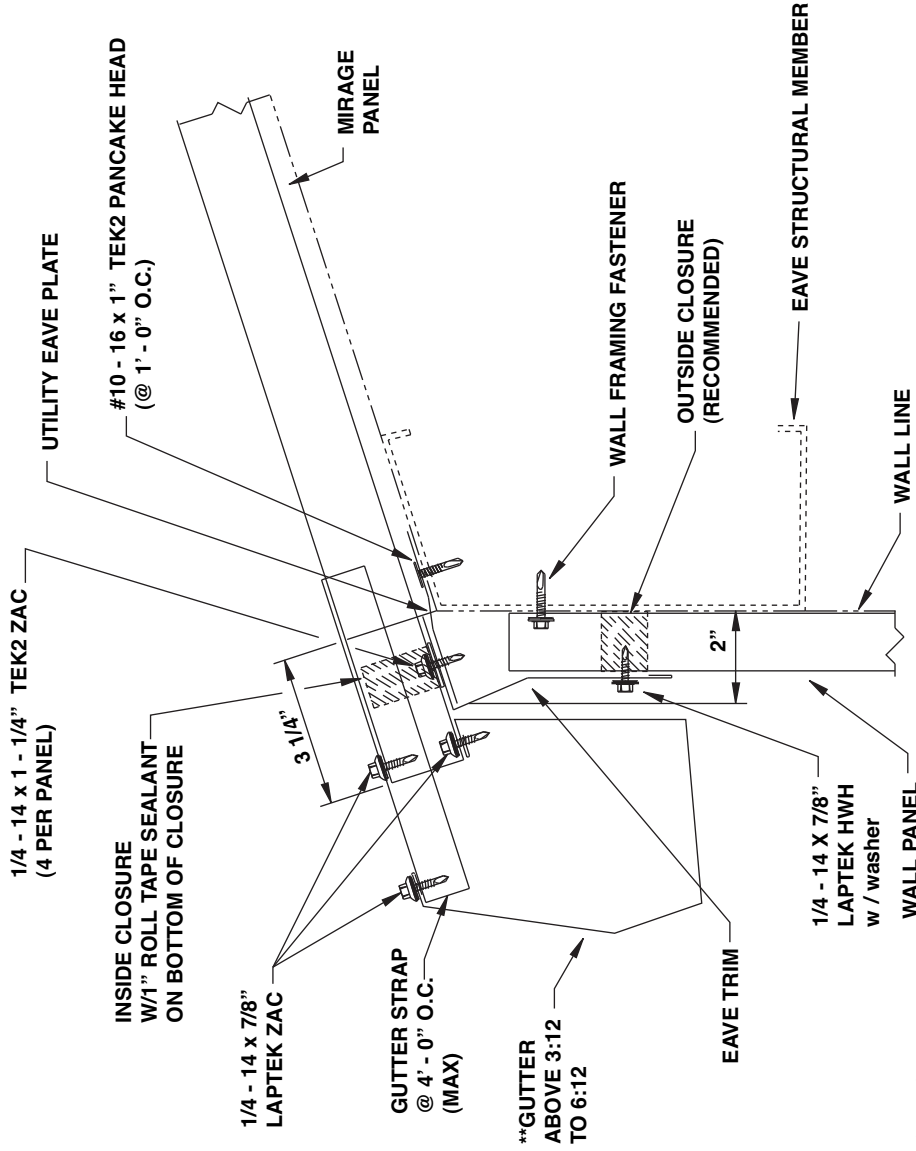

NOTES

1. Attach Utility Eave Plate with face edge 2" outside of building wall line using the #10 - 16 x 1" TEK2 Pancake Head at 1' - 0" O.C. to Eave Strut.
2. Attach Eave Trim to Utility Eave Plate with the #10 - 16 x 1" TEK2 Pancake Head at 4' - 0" O.C. and to wall panel with the 1/4 - 14 X 7/8" LAPTEK HWH w / washer at major ribs.
3. Place Inside Closure with continuous run of Roll Tape Sealant on bottom and Butyl Tube Sealant on top of closure.
4. Attach Roof Panel to Utility Eave Plate with 1/4 - 14 x 1 - 1/4" TEK2 ZAC. Fasteners must penetrate sealant.
5. Attach Gutter Strap to Roof Panel with 1/4 - 14 x 7/8" LAPTEK ZAC. Straps spaced at 4' - 0" (Max.).
6. Attach Gutter to Roof Panel with 1/4 - 14 x 7/8" LAPTEK ZAC at 8" O.C. and to Gutter Strap with 1/4 - 14 x 7/8" LAPTEK ZAC.

**Snow guards required to prevent damage caused by sliding snow.

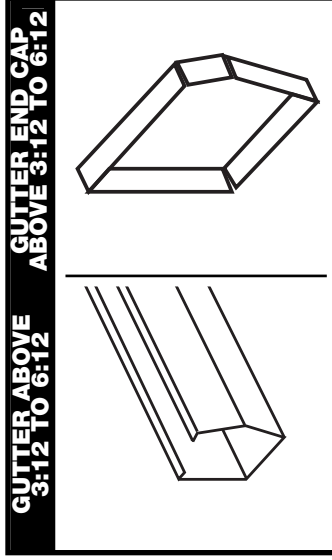
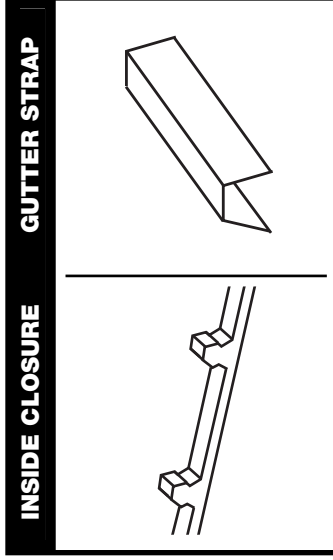
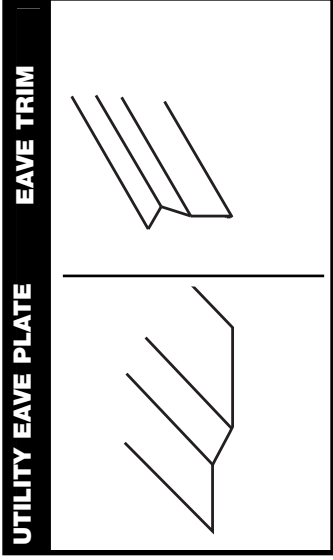

M c E l r o y M e t a l

**Mirage
GUTTER TRIM OVER 3:12
TO 6:12 DETAIL**

Technical Service: 1-800-950-9082

COMPRESSION BLANKET
INSULATION NOT
SHOWN FOR CLARITY

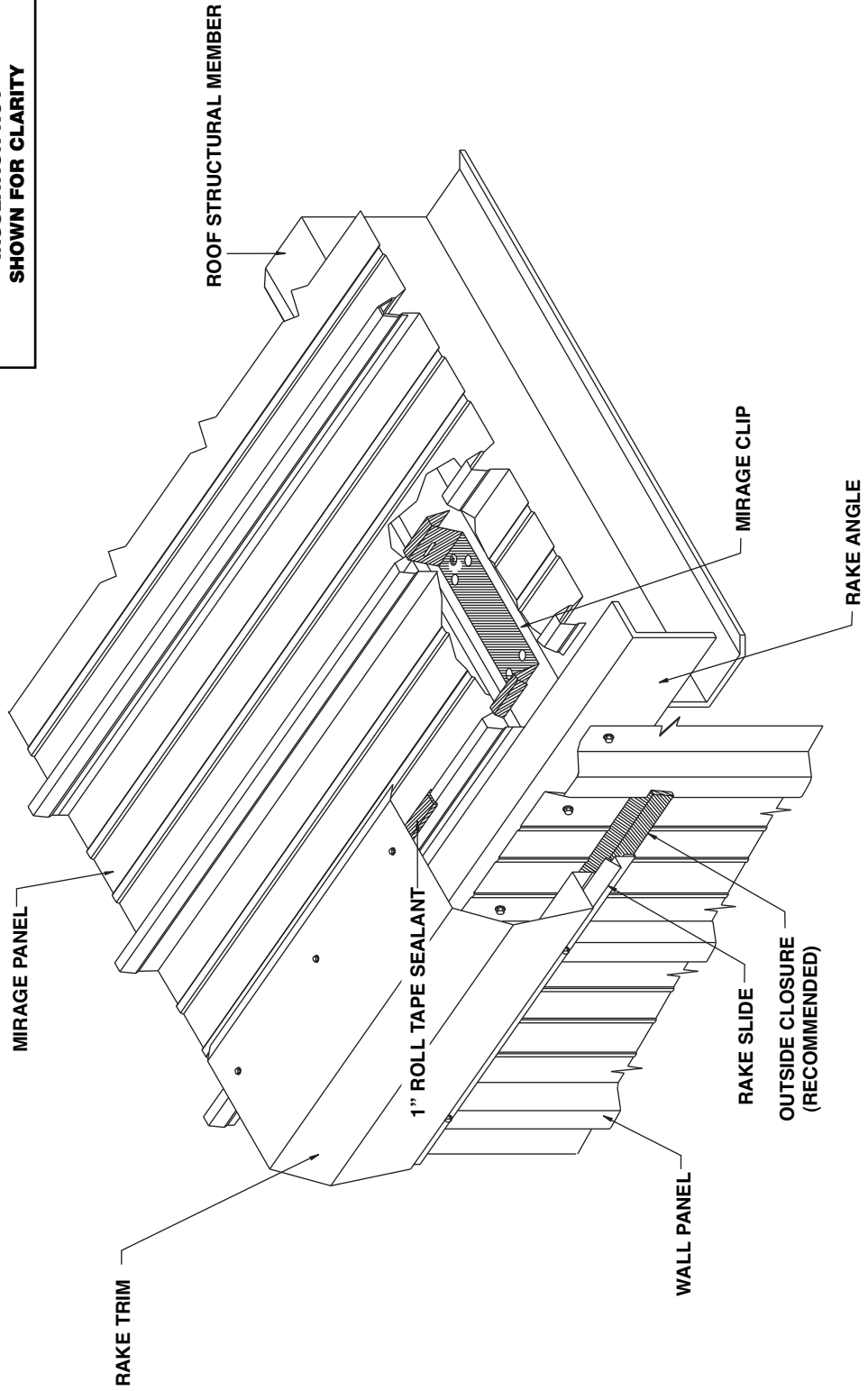

McElroy Metal

Mirage
RAKE START

Technical Service: 1-800-950-9082

INSTALLER NOTE: LOCATION OR ADJUSTING OF STARTING PANEL CAN VARY 1" OUTSIDE TO 2 1/2" INSIDE OF BUILDING LINE.

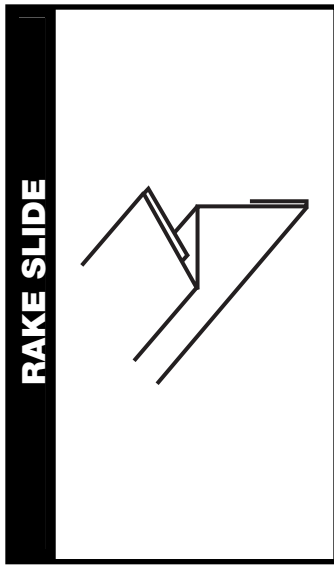
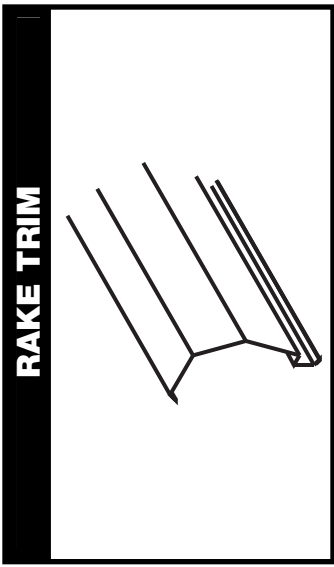
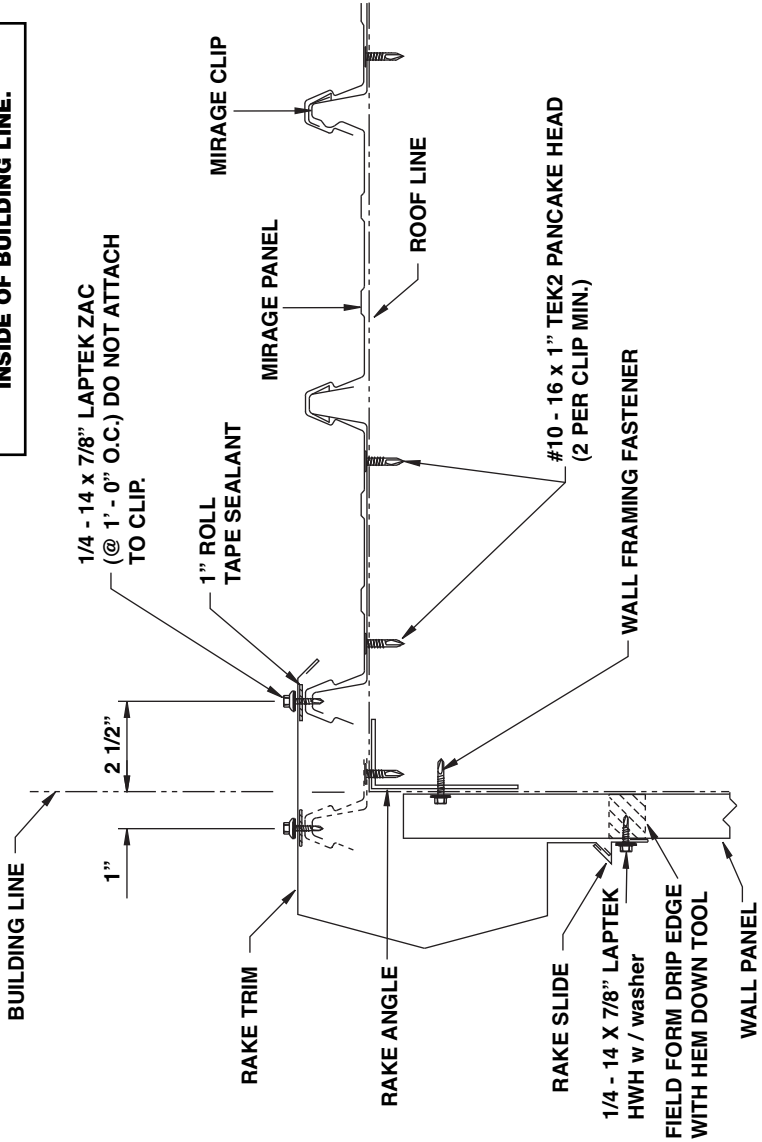

NOTES

1. Place a continuous run of Roll Tape Sealant on rib of Roof Panel.
2. Attach Rake to panel rib with 1/4 - 14 x 7/8" LAPTEK ZAC at 1' - 0" O.C. DO NOT ATTACH TO CLIP.
3. Place Rake Slide over Rake Trim Lip and attach to wall panel with 1/4 - 14 X 7/8" LAPTEK HWH w / washer at each major rib.

	<p>M c e l r o y M e t a l</p>
	<p>Mirage RAKE START DETAIL</p>
<p>Technical Service: 1-800-950-9082</p>	

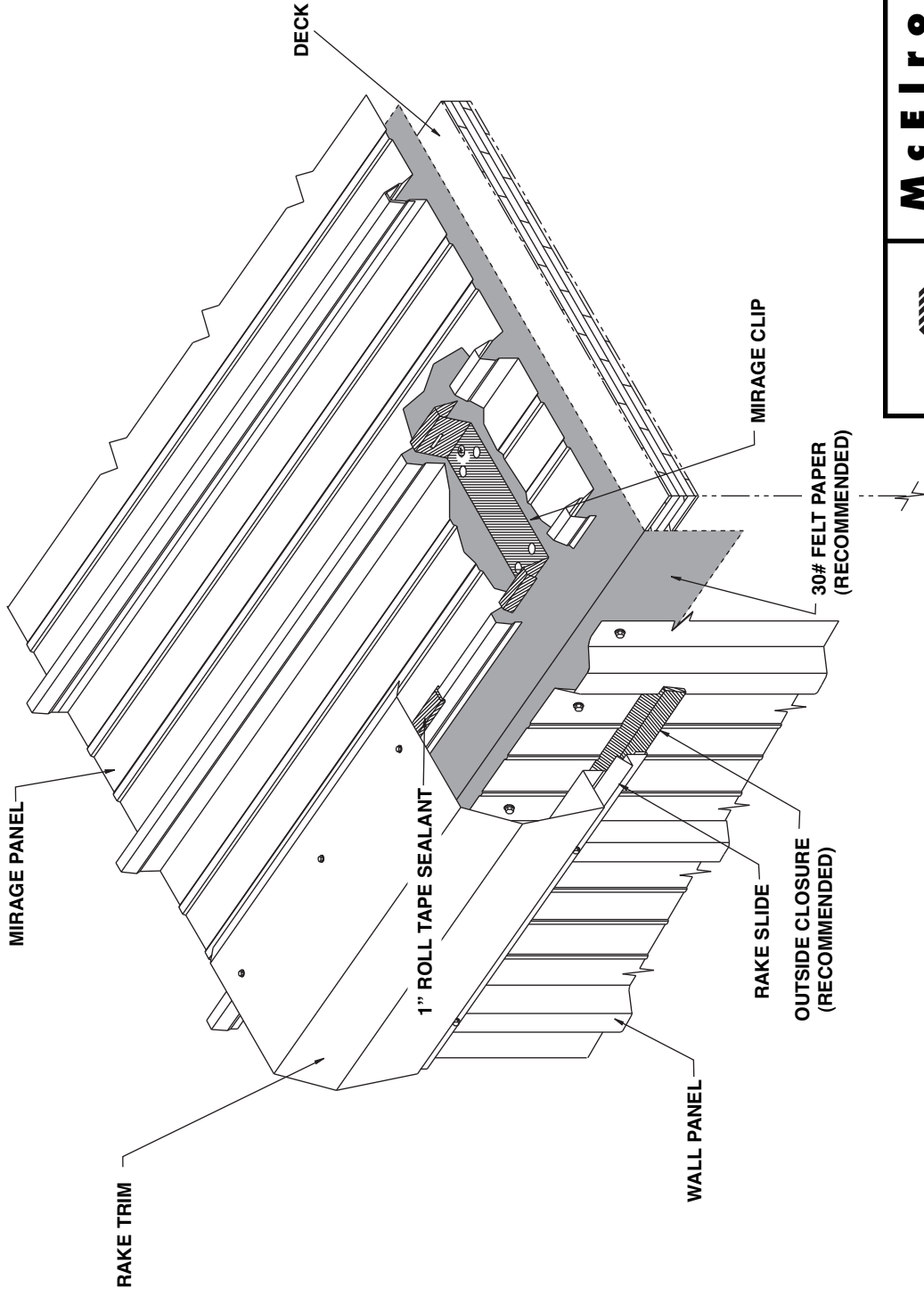

M c E l r o y M e t a l

**Mirage
RAKE START
W/DECK**

Technical Service: 1-800-950-9082

INSTALLER NOTE: LOCATION OR ADJUSTING OF STARTING PANEL CAN VARY 1" OUTSIDE TO 2 1/2" INSIDE OF BUILDING LINE.

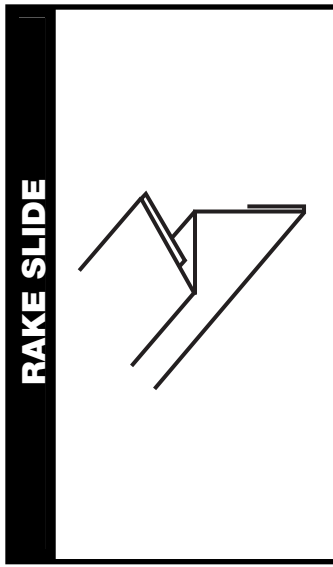
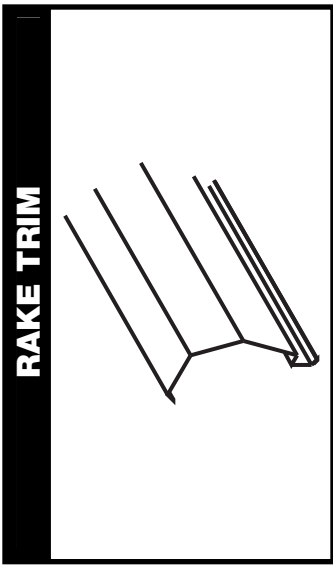
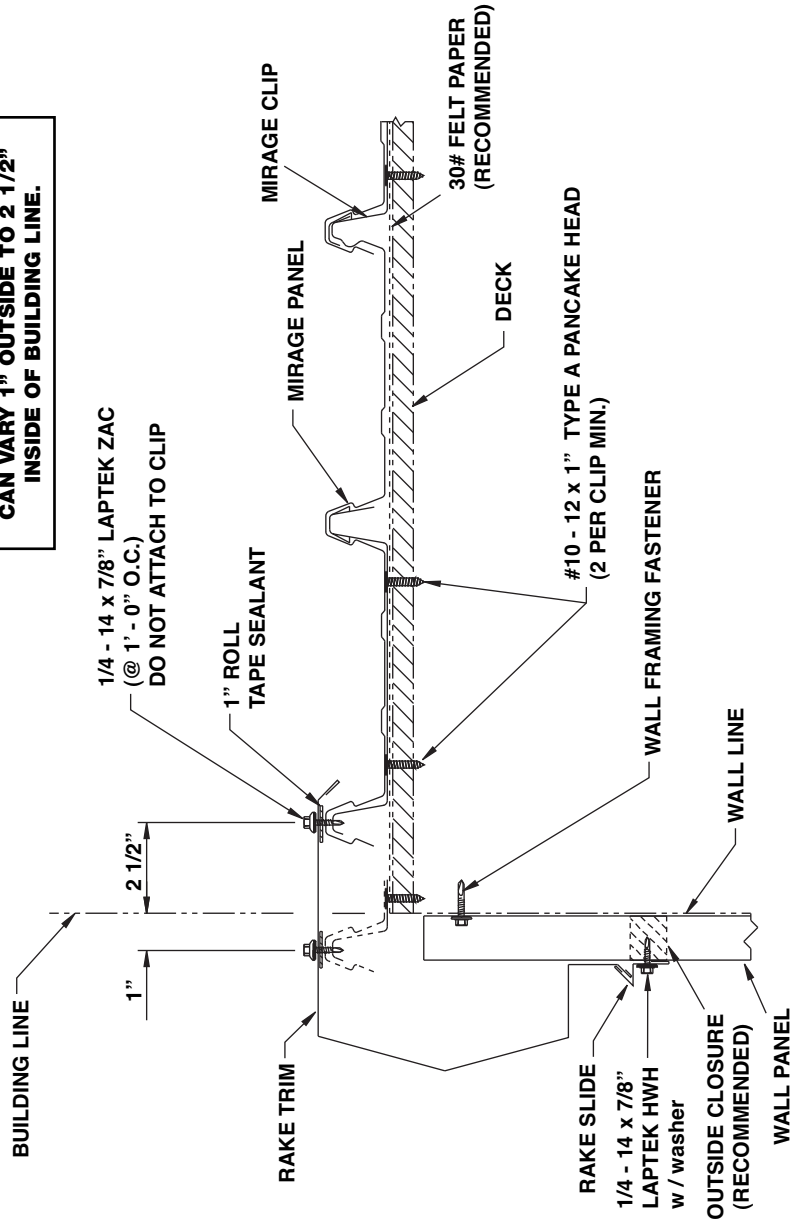

NOTES

1. Place a continuous run of Roll Tape Sealant on rib of Roof Panel.
2. Attach Rake to panel rib with 1/4 - 14 x 7/8" LAPTEK ZAC at 1' - 0" O.C. DO NOT ATTACH TO CLIP.
3. Place Rake Slide over Rake Trim Lip and attach to wall panel with 1/4 - 14 X 7/8" LAPTEK HWH w / washer at each major rib.



M c E l r o y M e t a l
Mirage
RAKE START
W/DECK DETAIL

COMPRESSIBLE BLANKET INSULATION NOT SHOWN FOR CLARITY

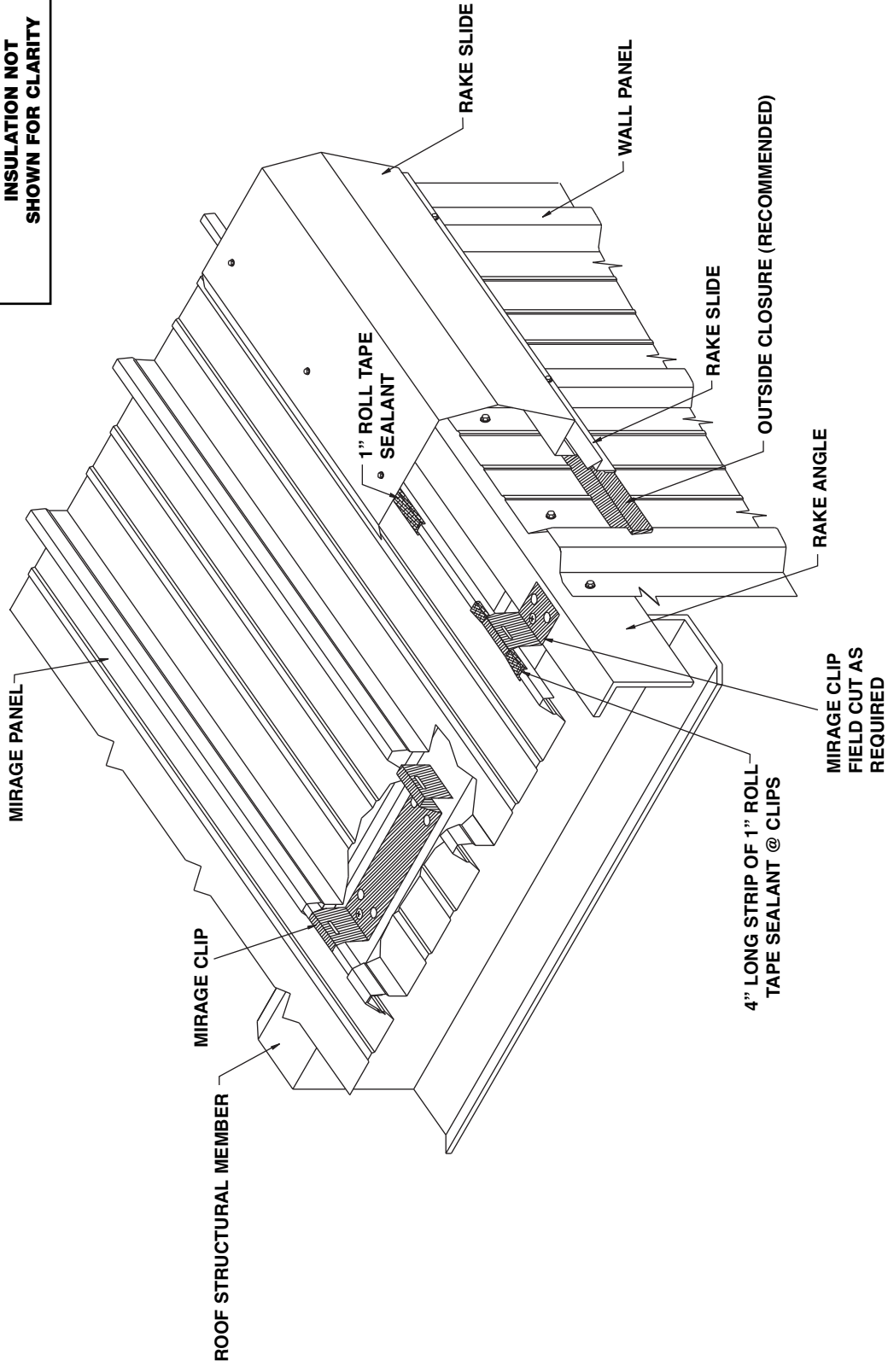

M c E l r o y M e t a l



Mirage
RAKE END

Technical Service: 1-800-950-9082

RAKE TRIM

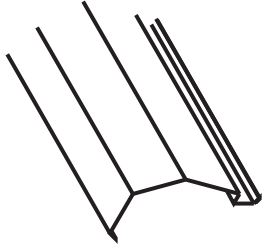

RAKE SLIDE

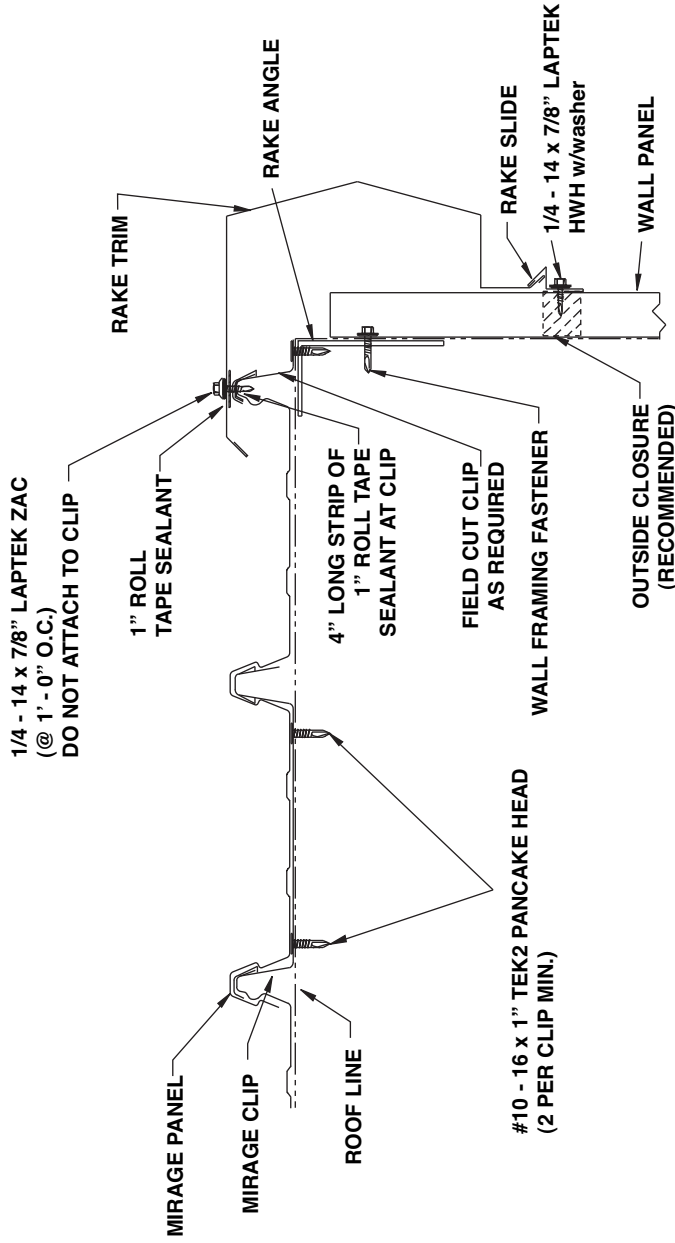
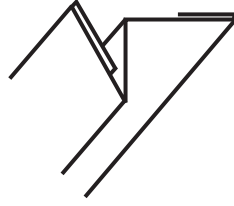

NOTES

1. Cut 4" long strips of Roll Tape Sealant and place on panel rib at each clip location before installing clip.
2. Place a continuous run of Roll Tape Sealant on rib of Roof Panel.
3. Attach Rake Trim to panel rib with 1/4 - 14 x 7/8" LAPTEK ZAC at 1' - 0" O.C. DO NOT ATTACH TO CLIP.
4. Place Rake Slide over Rake Trim Lip and attach to wall panel with 1/4 - 14 x 7/8" LAPTEK HWH w/washer at each major rib.



M c E l r o y M e t a l

**Mirage
RAKE END DETAIL**

Technical Service: 1-800-950-9082

COMPRESSIBLE BLANKET
INSULATION NOT
SHOWN FOR CLARITY

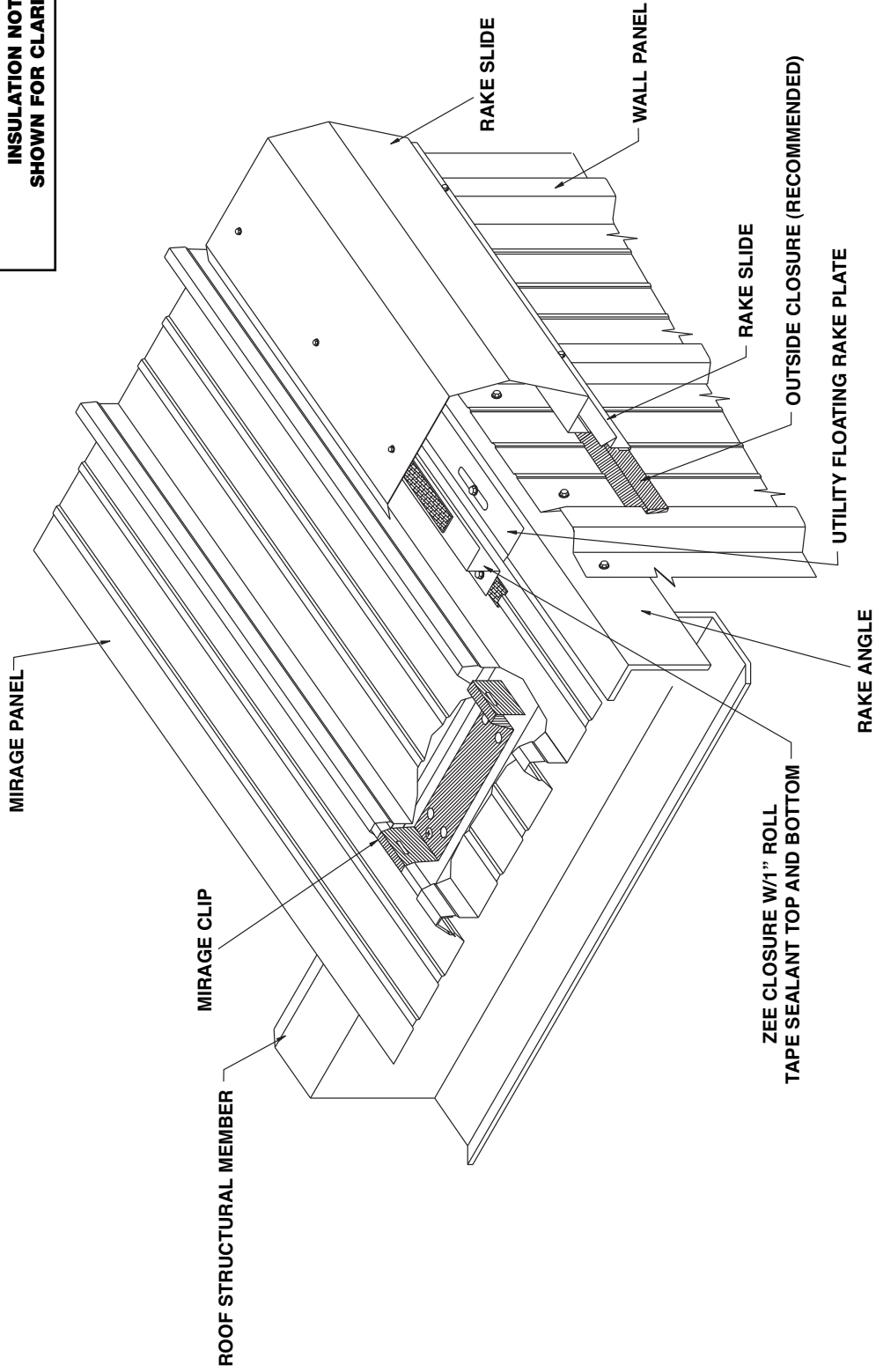

M c E l r o y M e t a l



Mirage
ALTERNATE RAKE END

Technical Service: 1-800-950-9082

UTILITY FLOATING RAKE PLATE

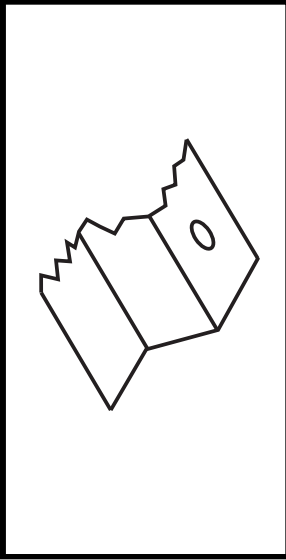

ZEE CLOSURE

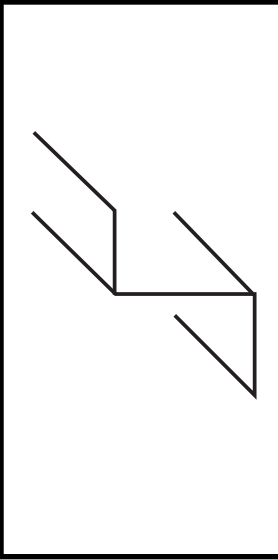

RAKE TRIM

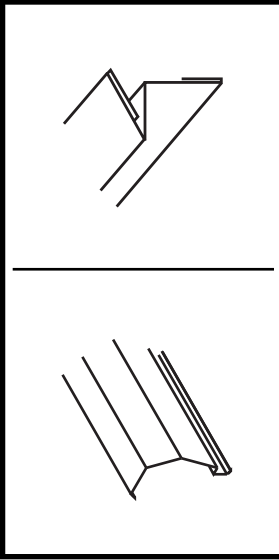

RAKE SLIDE

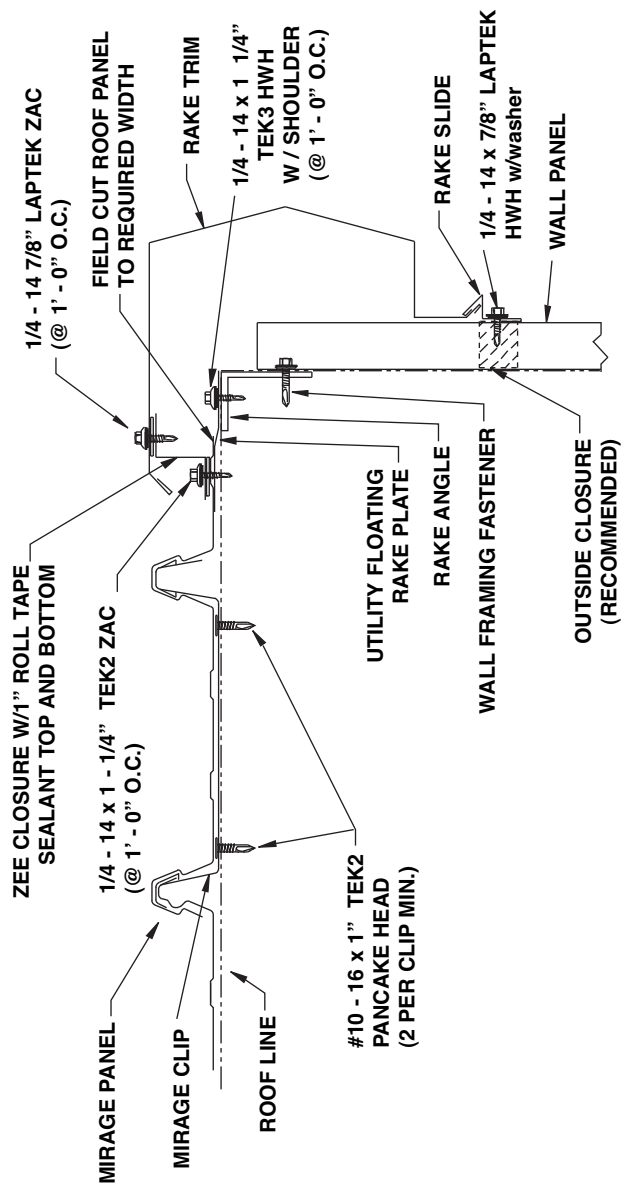
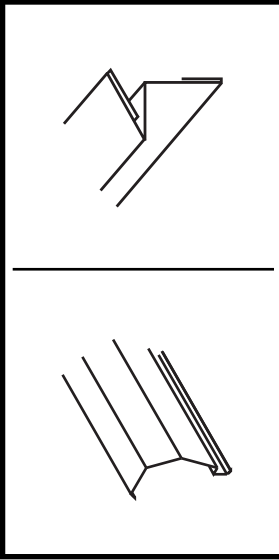

NOTES

1. Attach Utility Floating Rake Plate to Rake Angle with 1/4 - 14 x 1 1/4" TEK3 HWH w / shoulder at 1' - 0" O.C.
2. Field cut Mirage panel to required width and install.
3. Attach Zee Closure with 1" Roll Tape Sealant top and bottom to Utility Floating Rake Plate with 1/4 - 14 x 1 - 1/4" TEK2 ZAC at 1' - 0" O.C.
4. Attach Rake Trim to Zee Closure with 1/4 - 14 x 7/8" LAPTEK ZAC at 1' - 0" O.C.
5. Place Rake Slide over Rake Trim Lip and attach to wall with 1/4 - 14 x 7/8" LAPTEK HWH w/washer at each major rib.



M c E l r o y M e t a l

**Mirage
ALTERNATE RAKE END
DETAIL**

Technical Service: 1-800-950-9082

COMPRESSIBLE BLANKET
INSULATION NOT
SHOWN FOR CLARITY

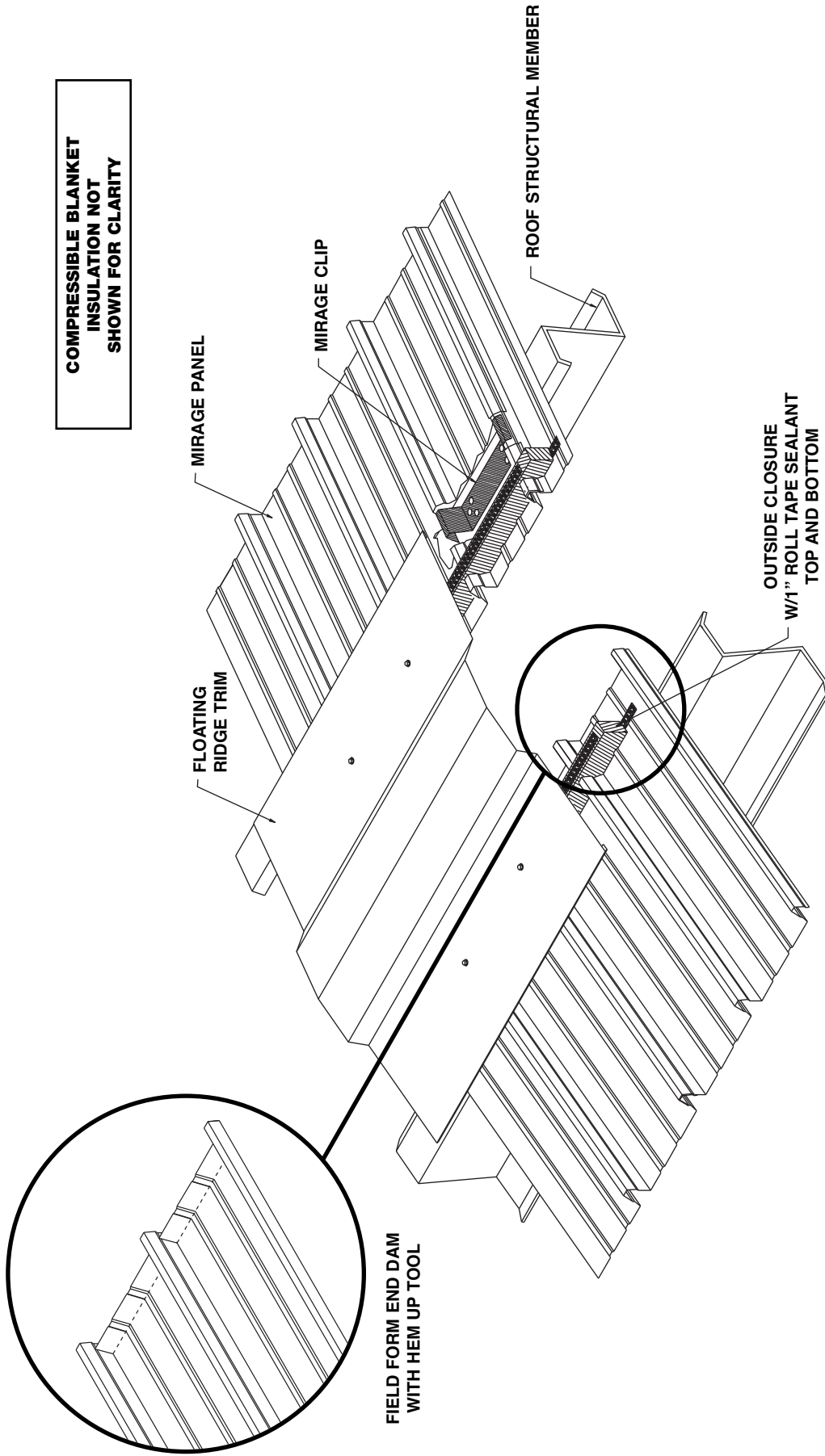

M c E l r o y M e t a l

**Mirage
FLOATING RIDGE**

Technical Service: 1-800-950-9082

FIELD FORM END DAM
WITH HEM UP TOOL

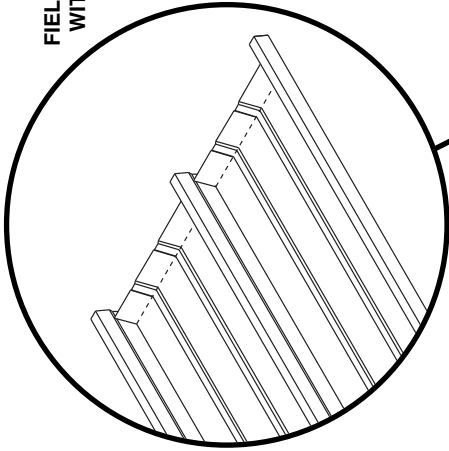

OUTSIDE CLOSURE

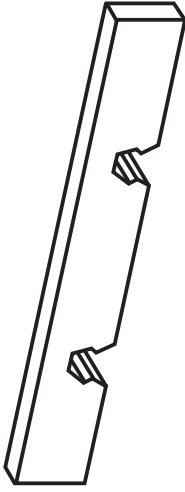

OUTSIDE CLOSURE
W/1" ROLL TAPE SEALANT
TOP AND BOTTOM

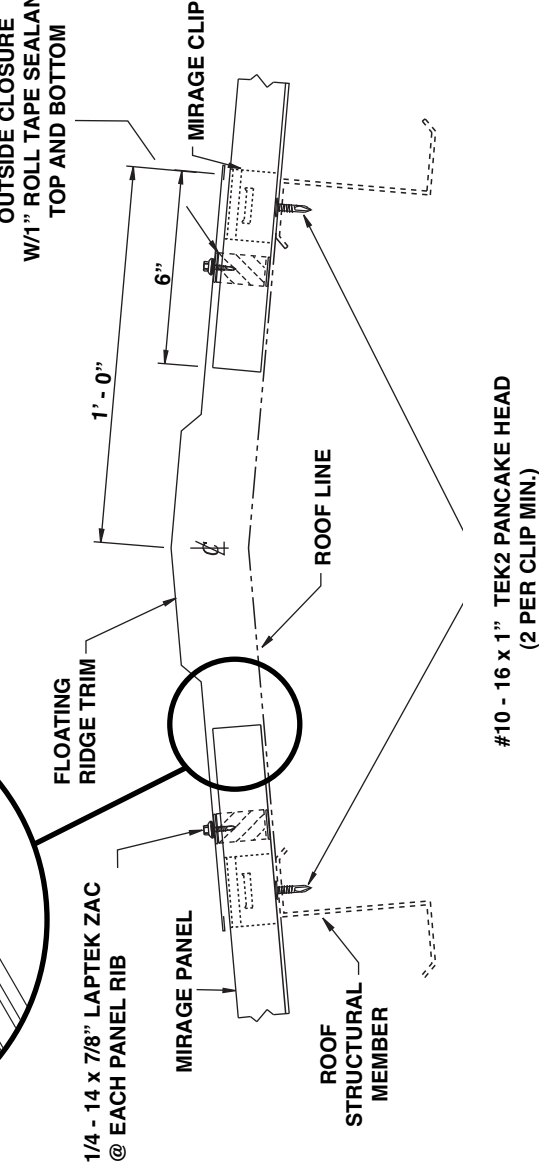

1/4 - 14 x 7/8" LAPTEK ZAC
@ EACH PANEL RIB

FLOATING RIDGE TRIM

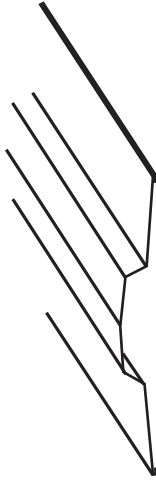

NOTES

1. Place Outside Closure with continuous run of Roll Tape Sealant on top and bottom of Closure.
2. Attach Floating Ridge Trim to each panel rib with 1/4 - 14 x 7/8" LAPTEK ZAC. Fasteners must penetrate sealant.



McElroy Metal

**Mirage
FLOATING RIDGE
DETAIL**

Technical Service: 1-800-950-9082

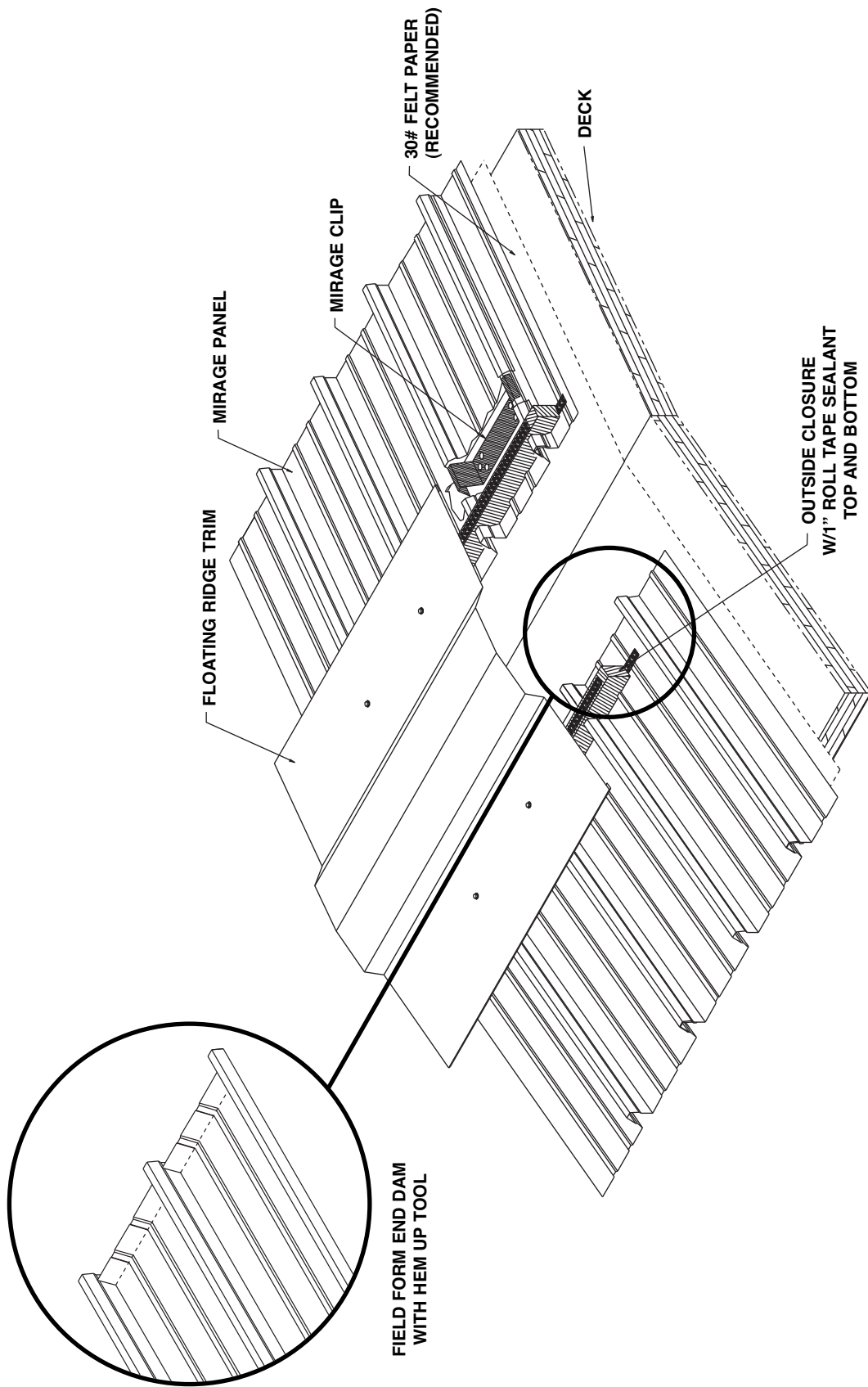

McElroy Metal

**Mirage
FLOATING RIDGE
W/DECK**

Technical Service: 1-800-950-9082

OUTSIDE CLOSURE

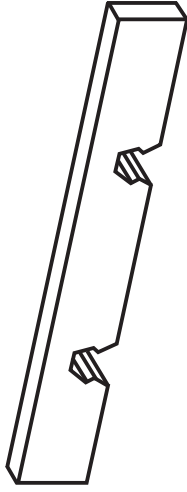

FLOATING RIDGE TRIM

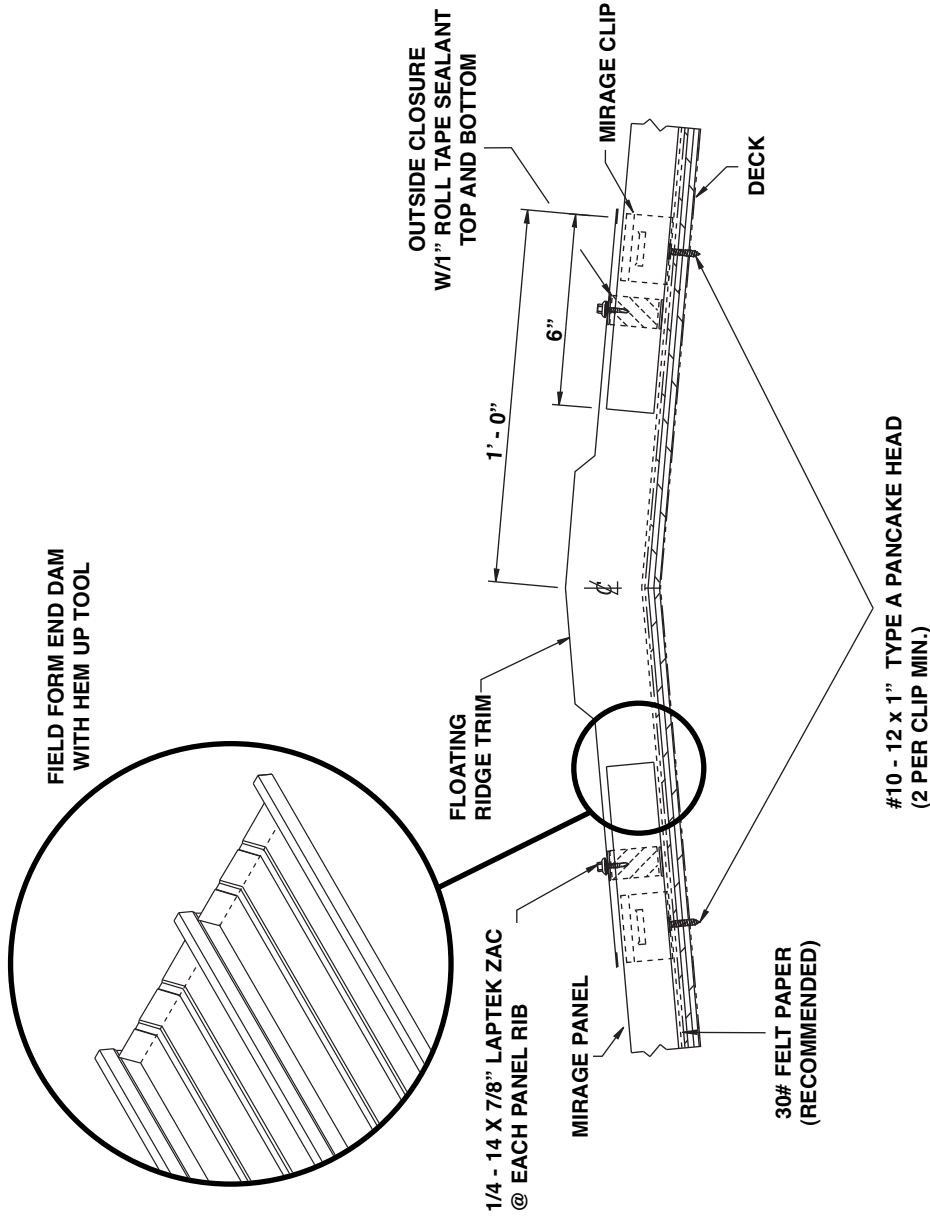
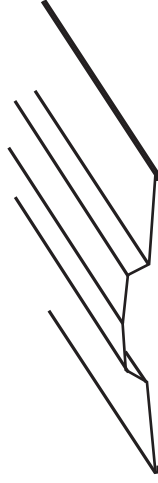

NOTES

1. Place Outside Closure with 1" Roll Tape Sealant on top and bottom of Closure.
2. Attach Floating Ridge Trim with 1/4 - 14 x 7/8" LAPTEK ZAC at each major rib. Fasteners must penetrate sealant.



M c E l r o y M e t a l

**Mirage
FLOATING RIDGE
W/DECK DETAIL**

Technical Service: 1-800-950-9082

COMPRESSIBLE BLANKET
INSULATION NOT
SHOWN FOR CLARITY

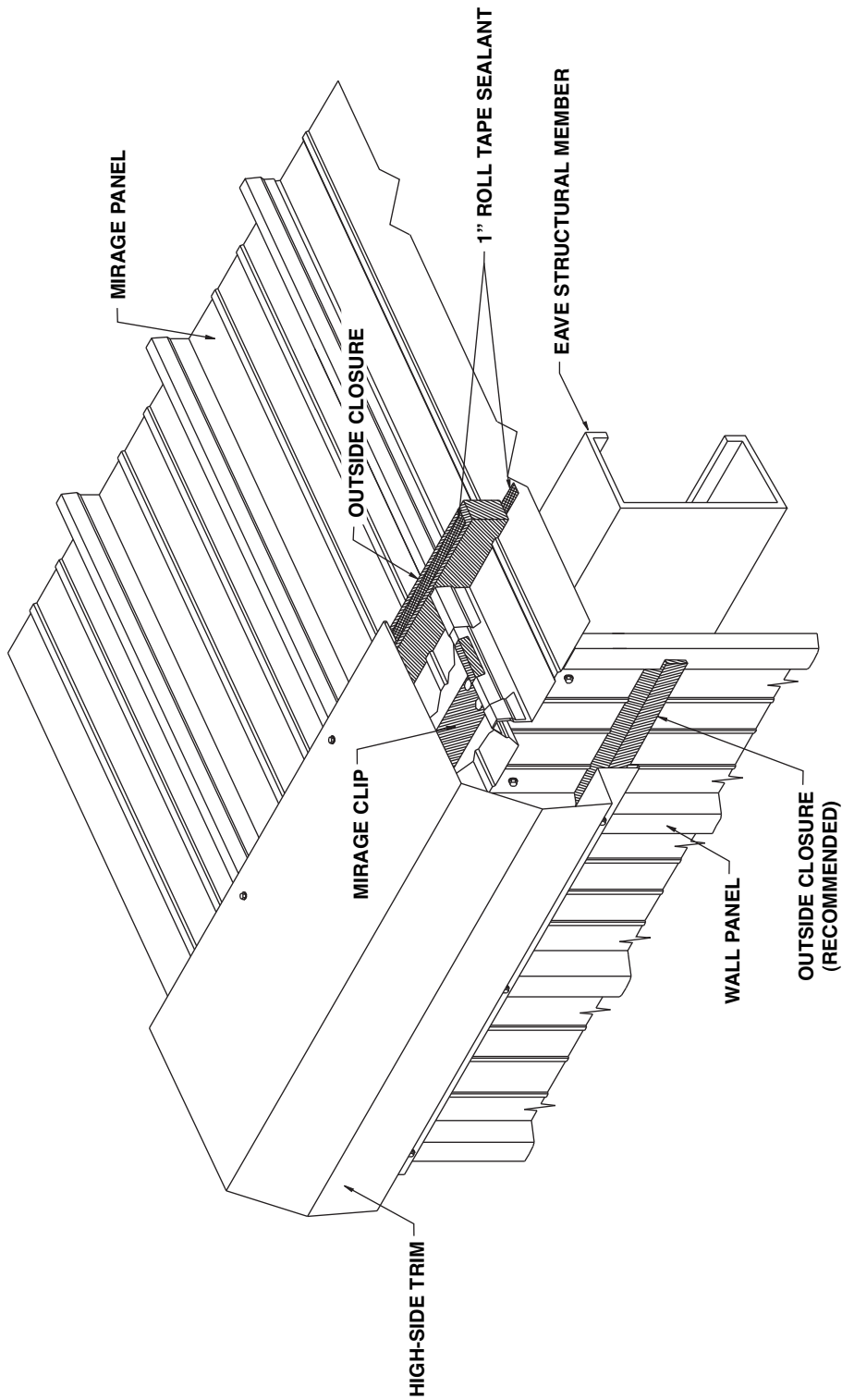

M c E I r o y M e t a l

Mirage
HIGH-SIDE TRIM

Technical Service: 1-800-950-9082

OUTSIDE CLOSURE

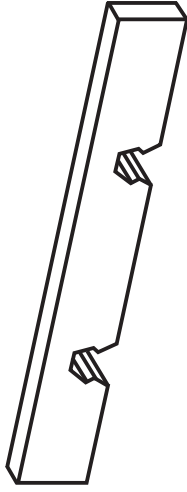

HIGH-SIDE TRIM

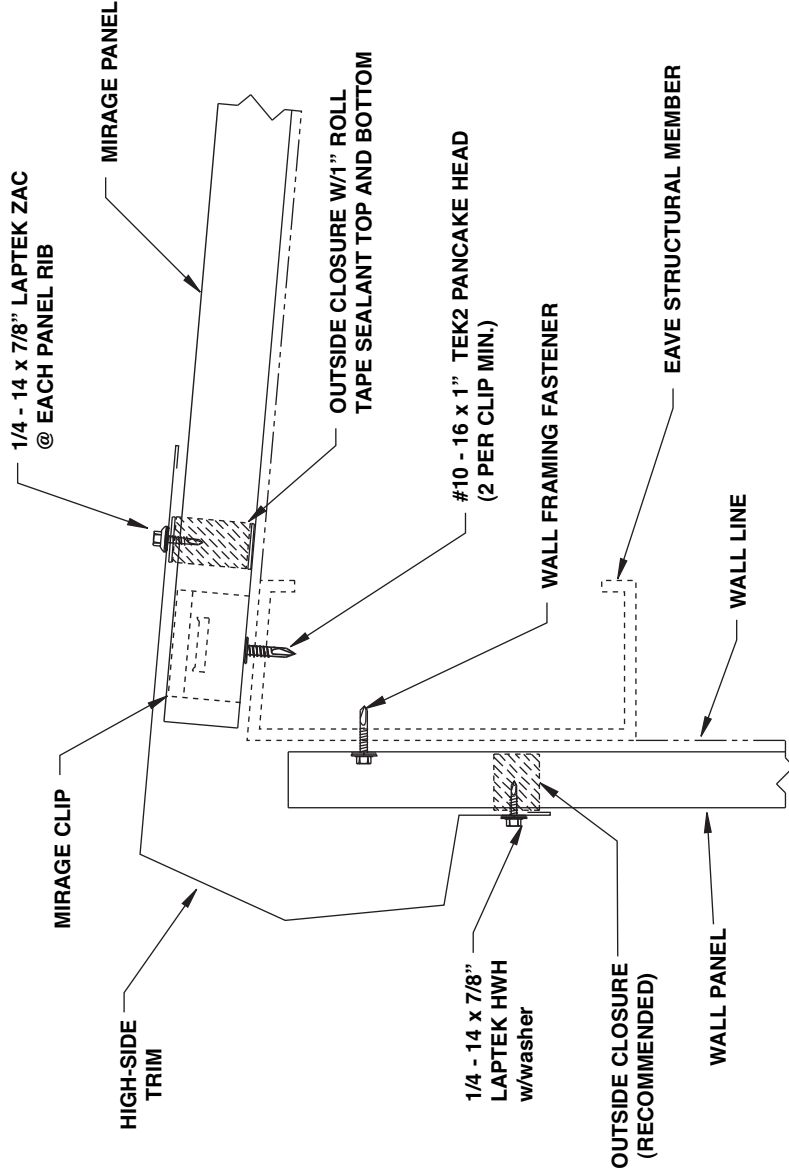
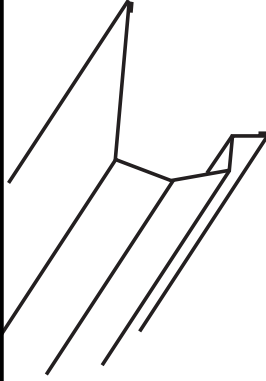

NOTES

1. Place Outside Closure with continuous run of Roll Tape Sealant on top and bottom of closure.
2. Attach High Side Trim to each panel rib with 1/4 - 14 x 7/8" LAPTEK ZAC. Fasteners must penetrate sealant. Attach to wall panel with 1/4 - 14 x 7/8" LAPTEK HWH w/washer at each minor rib.



M c E l r o y M e t a l

**Mirage
HIGH-SIDE TRIM
DETAIL**

Technical Service: 1-800-950-9082

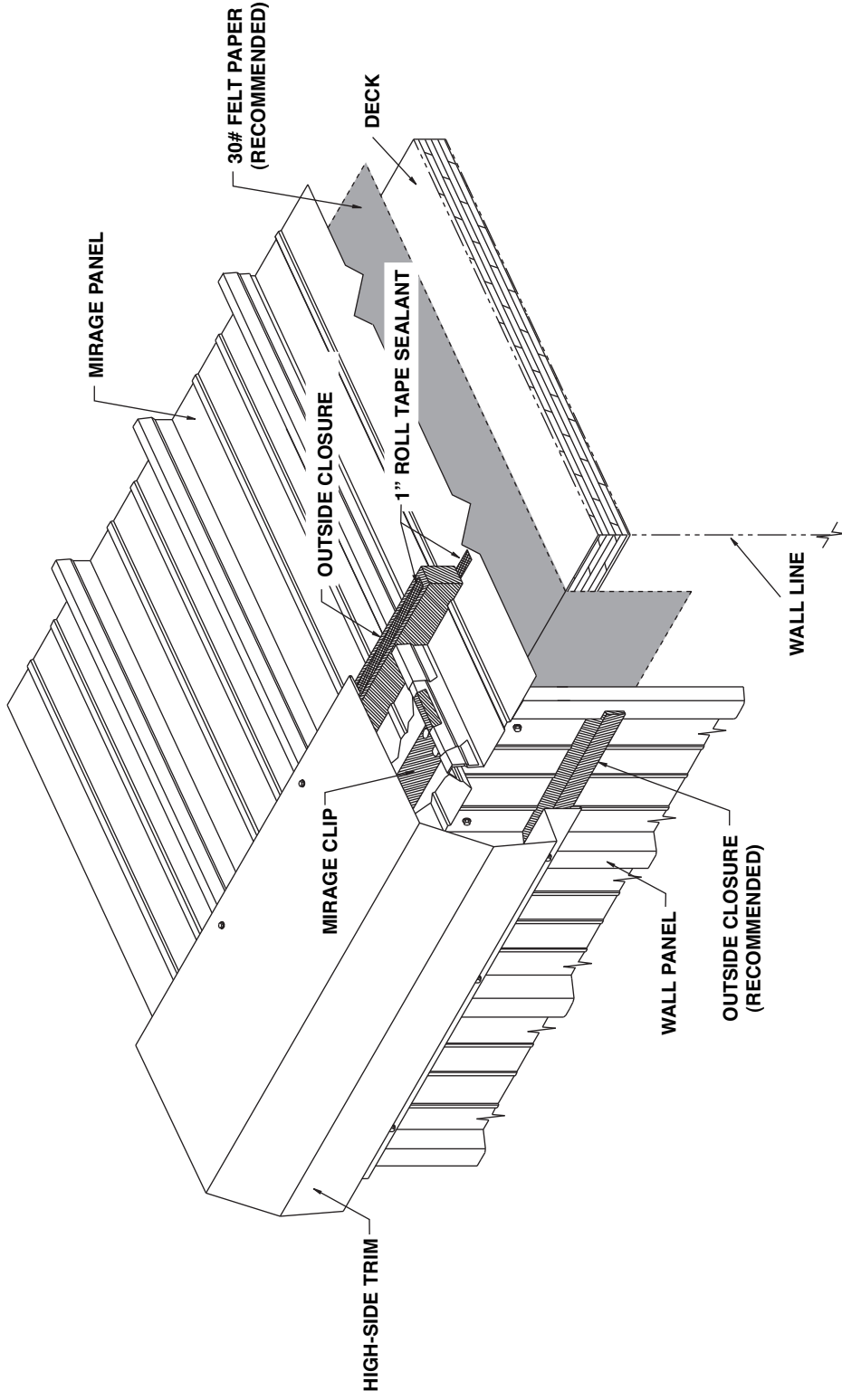

M c E l r o y M e t a l

**Mirage
HIGH-SIDE TRIM
W/DECK**

Technical Service: 1-800-950-9082

OUTSIDE CLOSURE

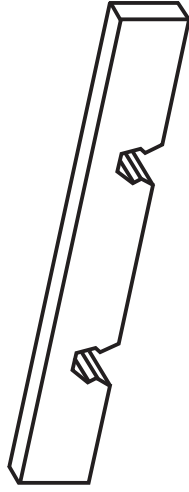

HIGH SIDE TRIM

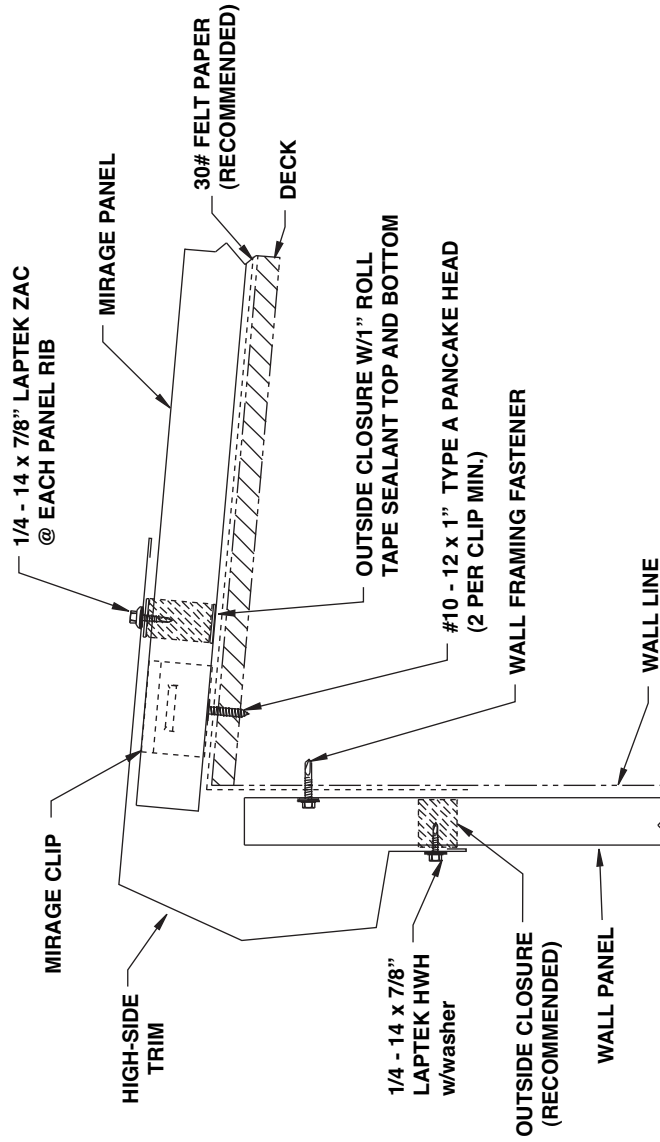
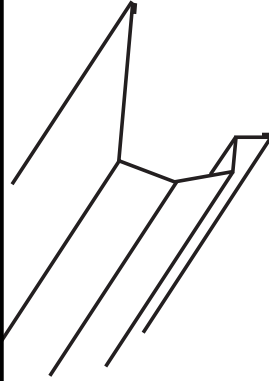

NOTES

1. Place Outside Closure with 1" Roll Tape Sealant on top and bottom of Closure.
2. Attach High Side Trim to Mirage Panel Rib with 1/4 - 14 x 7/8" LAPTEK ZAC to each major rib. Fasteners must penetrate sealant. Attach to wall panel with 1/4 - 14 x 7/8" LAPTEK HWH w/washer at each major rib.



M c E l r o y M e t a l

**Mirage
HIGH-SIDE TRIM
W/DECK DETAIL**

Technical Service: 1-800-950-9082

COMPRESSIBLE BLANKET
INSULATION NOT
SHOWN FOR CLARITY

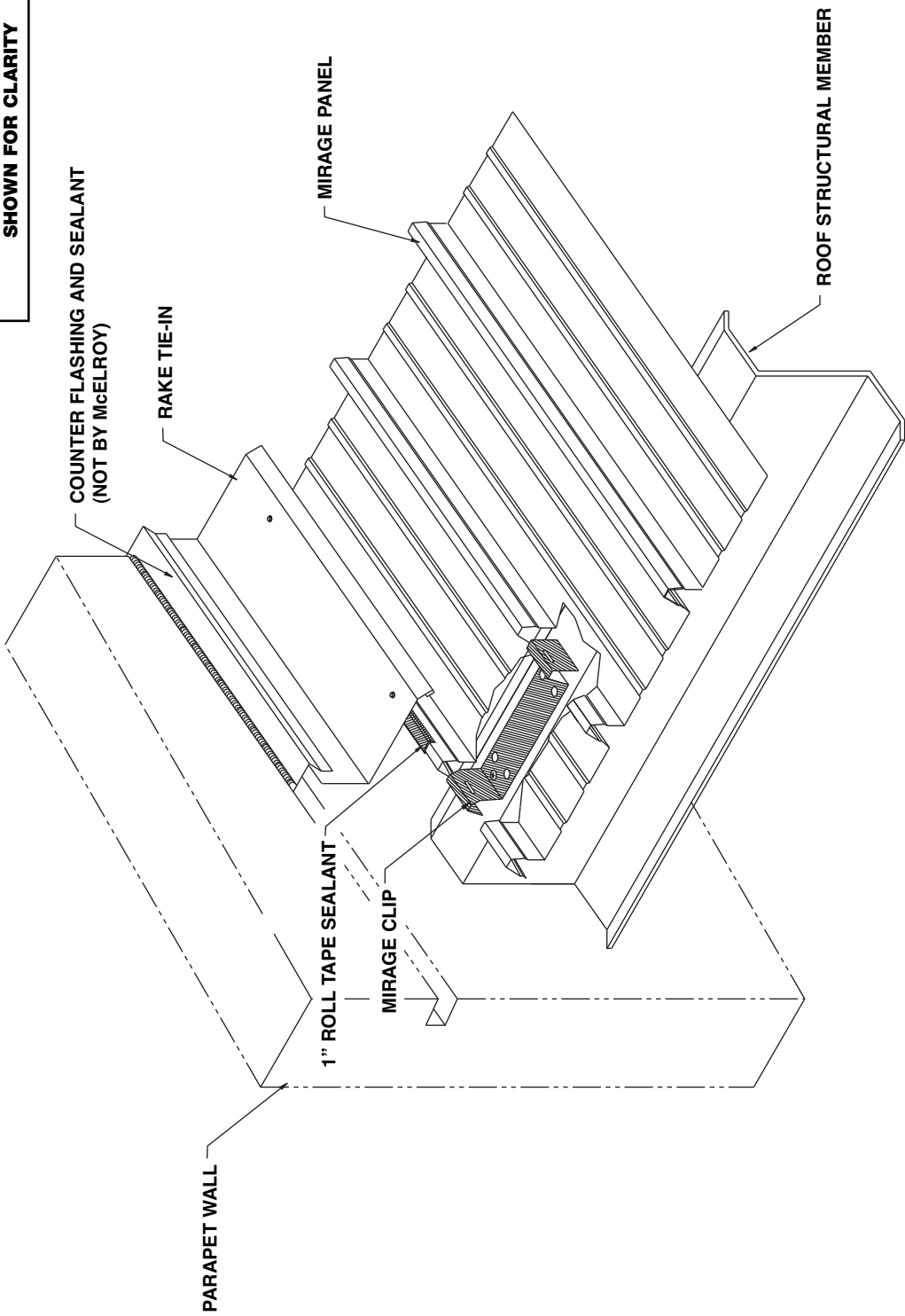

M c E l r o y M e t a l

Mirage
RAKE TIE-IN START

Technical Service: 1-800-950-9082

RAKE TIE-IN TRIM

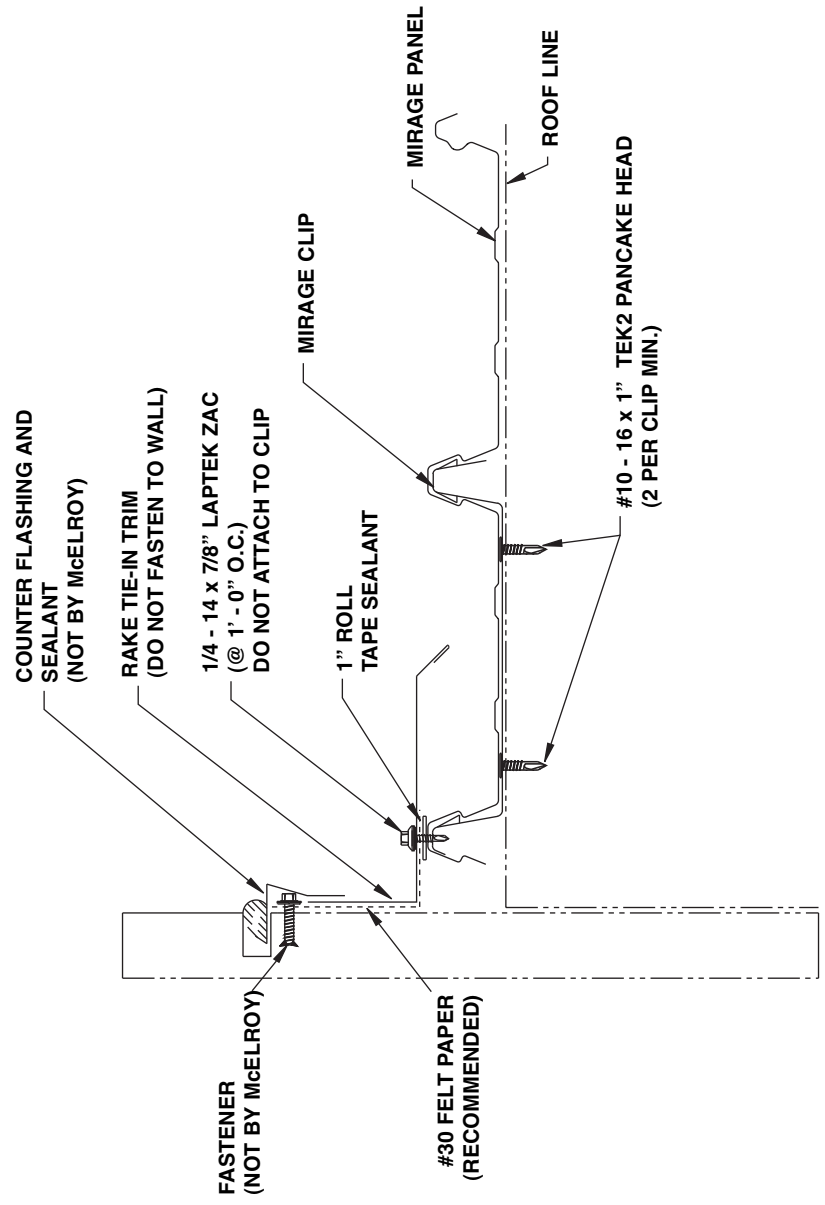
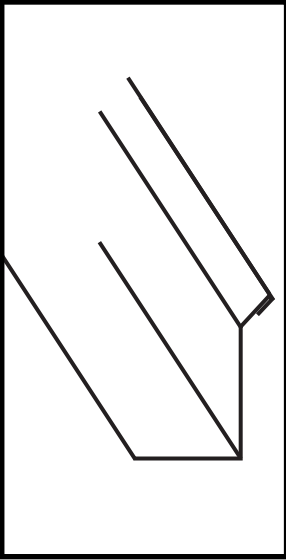

COUNTER FLASHING AND SEALANT (NOT BY McELROY)

RAKE TIE-IN TRIM (DO NOT FASTEN TO WALL)

1/4 - 14 x 7/8" LAPTEK ZAC (@ 1' - 0" O.C.) DO NOT ATTACH TO CLIP

MIRAGE CLIP

1" ROLL TAPE SEALANT

MIRAGE PANEL

#30 FELT PAPER (RECOMMENDED)

ROOF LINE

#10 - 16 x 1" TEK2 PANCAKE HEAD (2 PER CLIP MIN.)

NOTES

1. Place a continuous run of 1" Roll Tape Sealant on rib of roof panel.
2. Attach Rake Tie-In Trim to panel rib with 1/4 - 14 x 7/8" LAPTEK ZAC at 1' - 0" O.C. DO NOT ATTACH TO CLIP.



McElroy Metal

Mirage
**RAKE TIE-IN START
DETAIL**

Technical Service: 1-800-950-9082 44

COMPRESSION BLANKET
INSULATION NOT
SHOWN FOR CLARITY

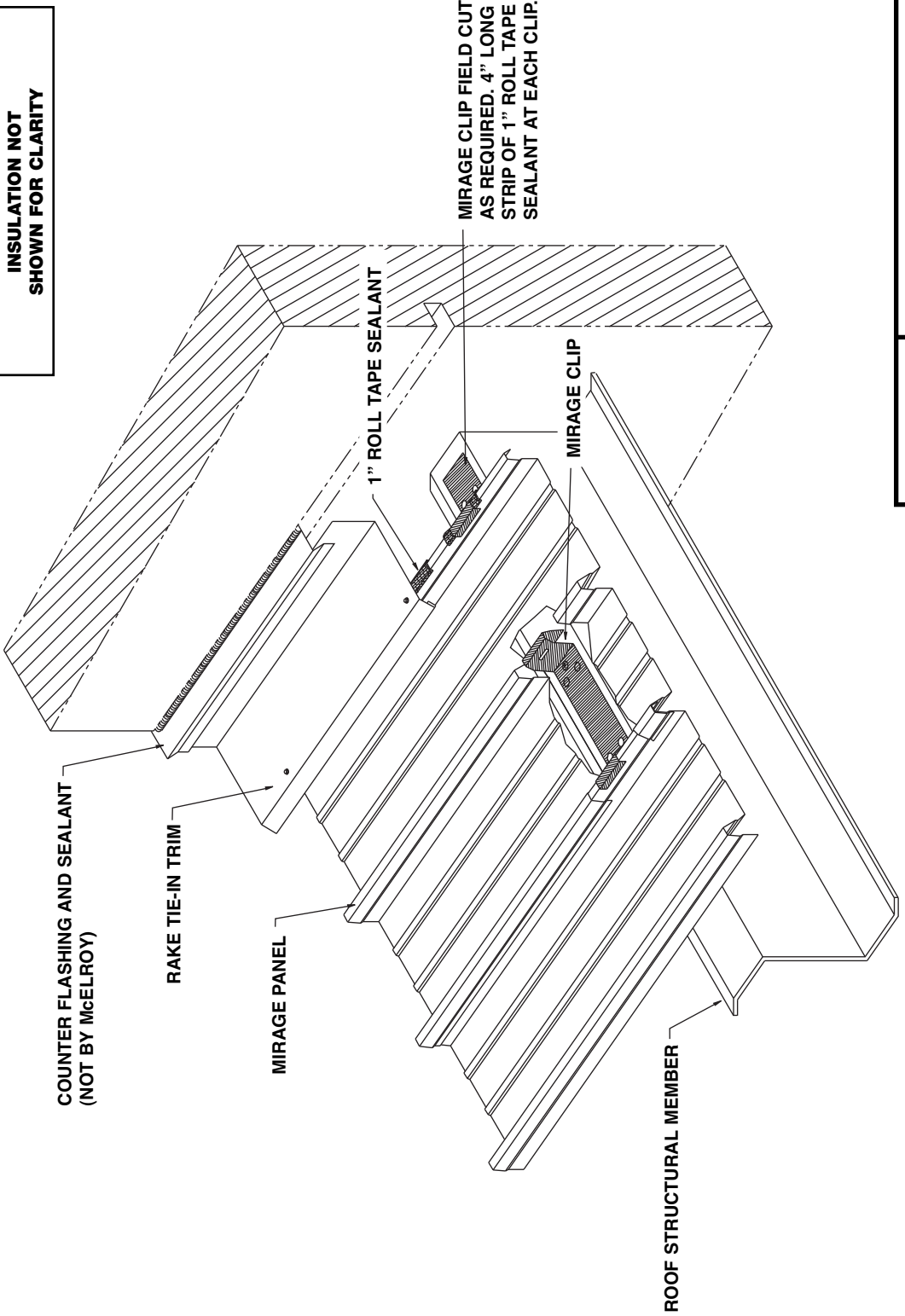

McElroy Metal

Mirage
RAKE TIE-IN END

Technical Service: 1-800-950-9082

RAKE TIE-IN TRIM

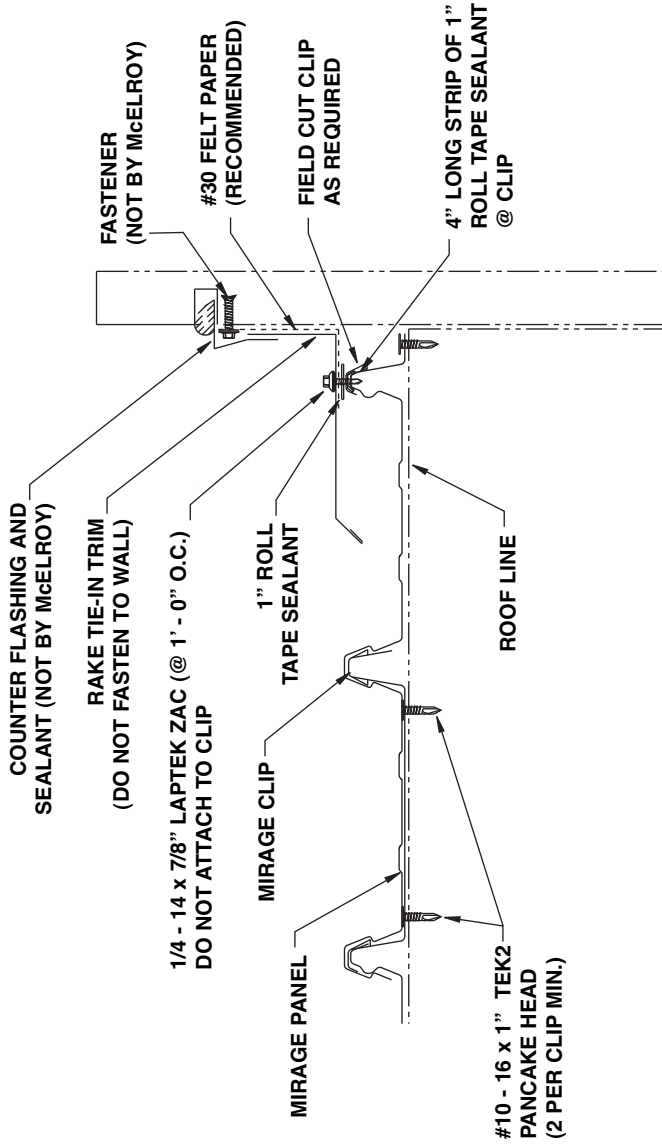
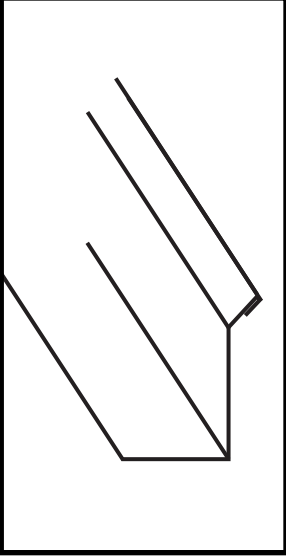

NOTES

1. Cut 4" long strip of 1" Roll Tape Sealant and place on panel rib at each clip location before installing clip.
2. Place a continuous run of Roll Tape Sealant on rib of roof panel.
3. Attach Rake Tie-In Trim to panel rib with 1/4 - 14 x 7/8" LAPTEK ZAC at 1' - 0" O.C. DO NOT ATTACH TO CLIP.



M c E l r o y M e t a l

Mirage
RAKE TIE-IN END
DETAIL

Technical Service: 1-800-950-9082

COMPRESSIBLE BLANKET INSULATION NOT SHOWN FOR CLARITY

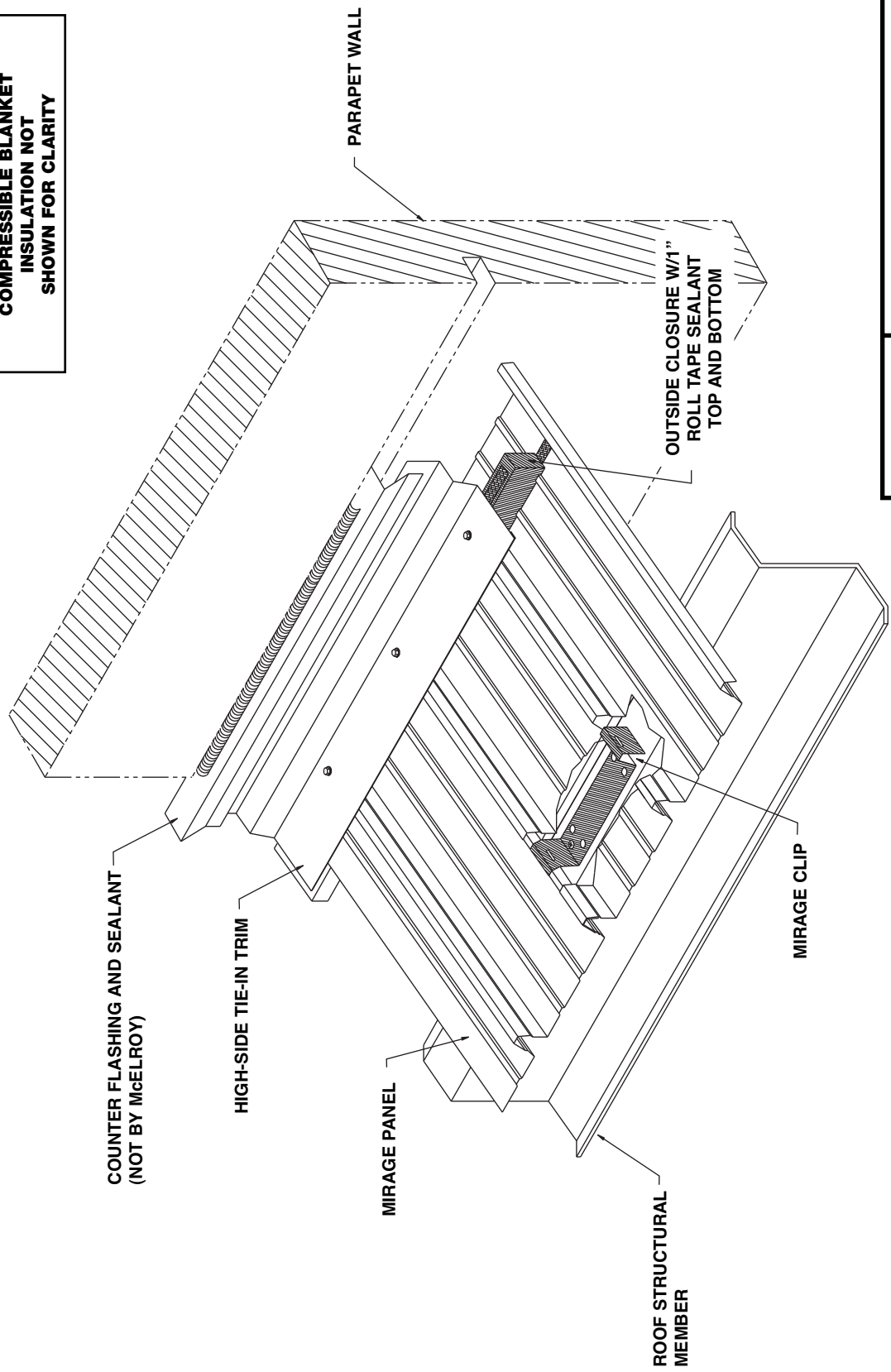

M c E l r o y M e t a l

**Mirage
HIGH-SIDE TIE-IN TRIM**

Technical Service: 1-800-950-9082

OUTSIDE CLOSURE

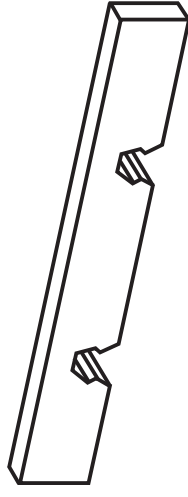

HIGH-SIDE TIE-IN TRIM

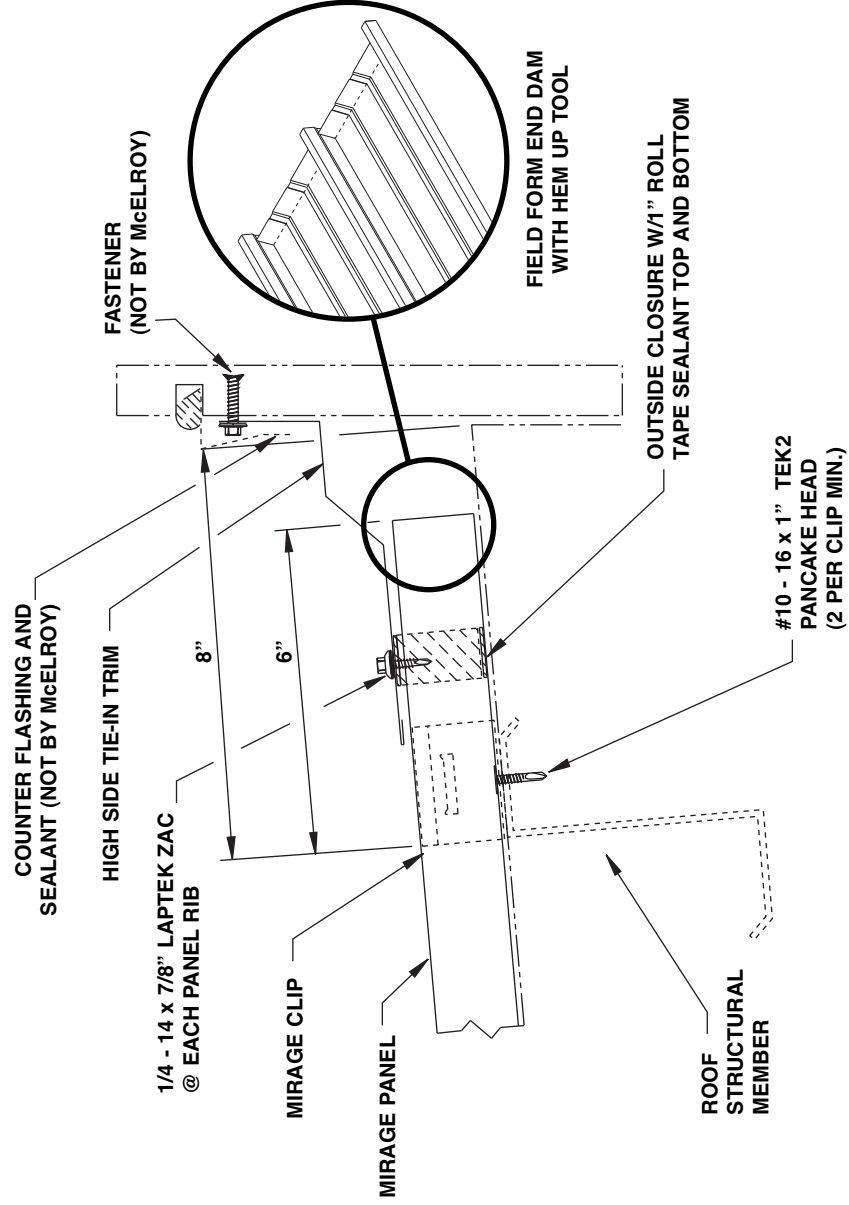
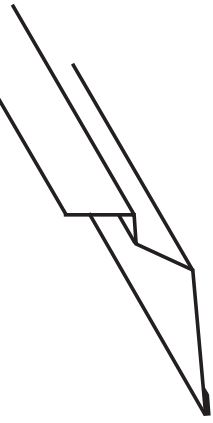

NOTES

1. Place Outside Closure with continuous run of 1" Roll Tape Sealant on top and bottom of closure.
2. Attach High Side Tie-In Trim to each panel rib with 1/4 - 14 x 7/8" LAPTEK ZAC. Fasteners must penetrate sealant.



McElroy Metal

**Mirage
HIGH-SIDE TIE-IN TRIM
DETAIL**

Technical Service: 1-800-950-9082

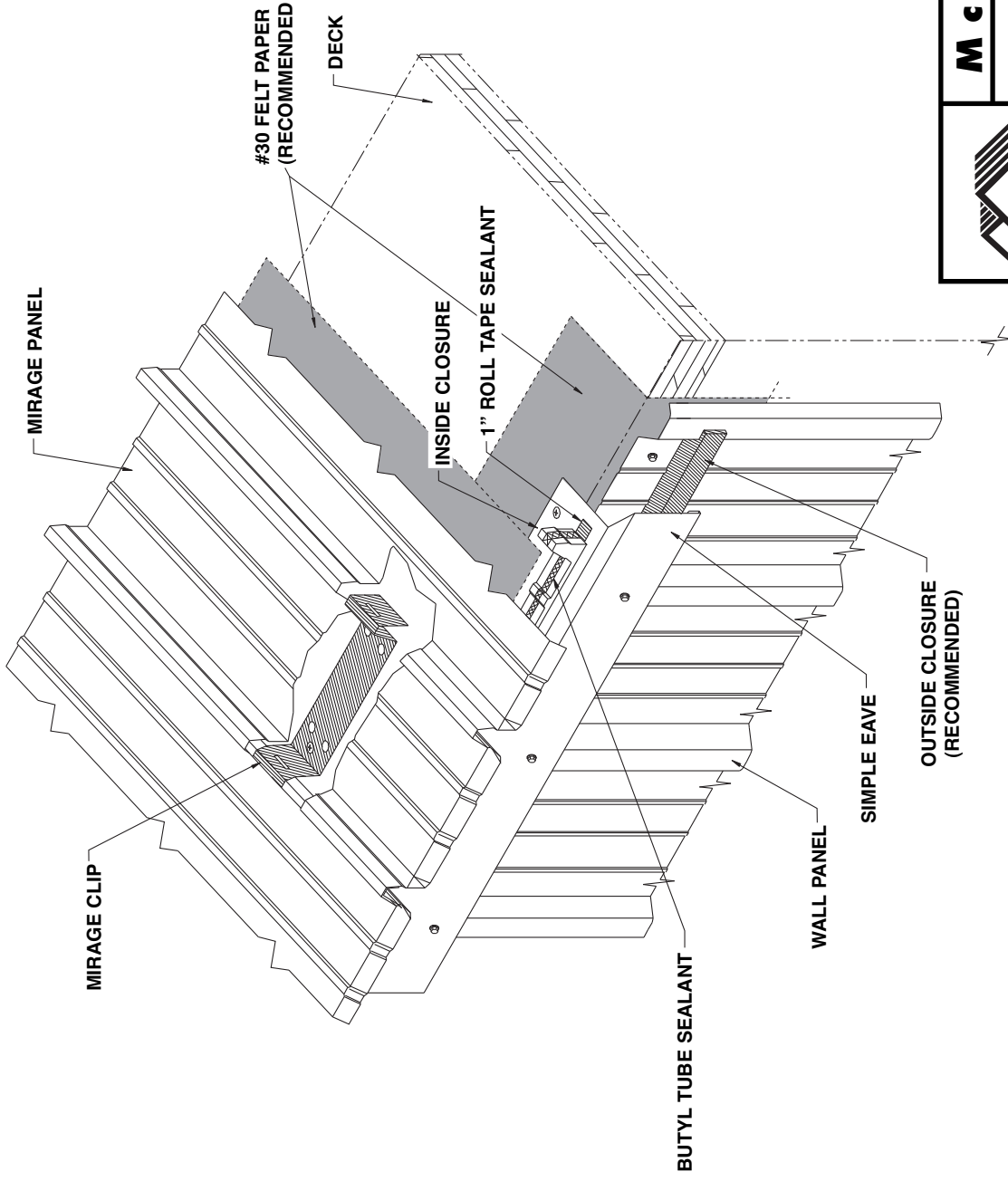

M c E l r o y M e t a l

**Mirage
FLOATING EAVE TRIM
W/DECK**

Technical Service: 1-800-950-9082

SIMPLE EAVE TRIM

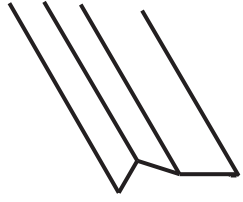

INSIDE CLOSURE

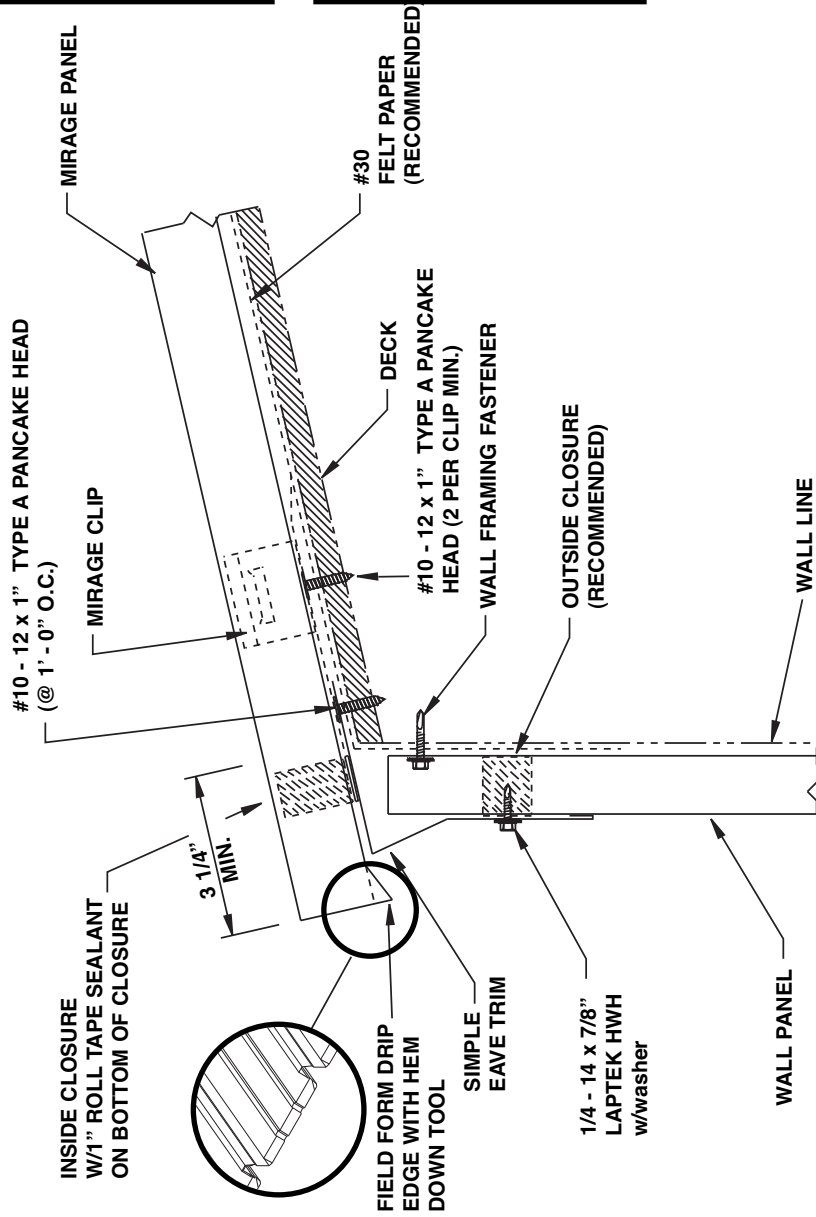
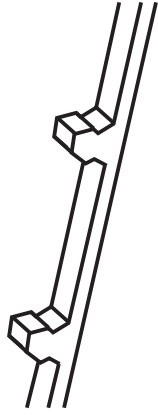

NOTES

1. Attach Simple Eave Trim to deck with #10 - 12 x 1" TYPE A PANCAKE HEAD at 1' - 0" O.C. and to wall panel with 1/4 - 14 x 7/8" LAPTEK HWH w/washer at major ribs.
2. Place Inside Closure with 1" Roll Tape Sealant on bottom and Butyl Tube Sealant on top of closure.
3. Install Mirage Panel. Field form Drip Edge on end of panel.



M c E l r o y M e t a l

**Mirage
FLOATING EAVE TRIM
W/DECK DETAIL**

Technical Service: 1-800-950-9082 50

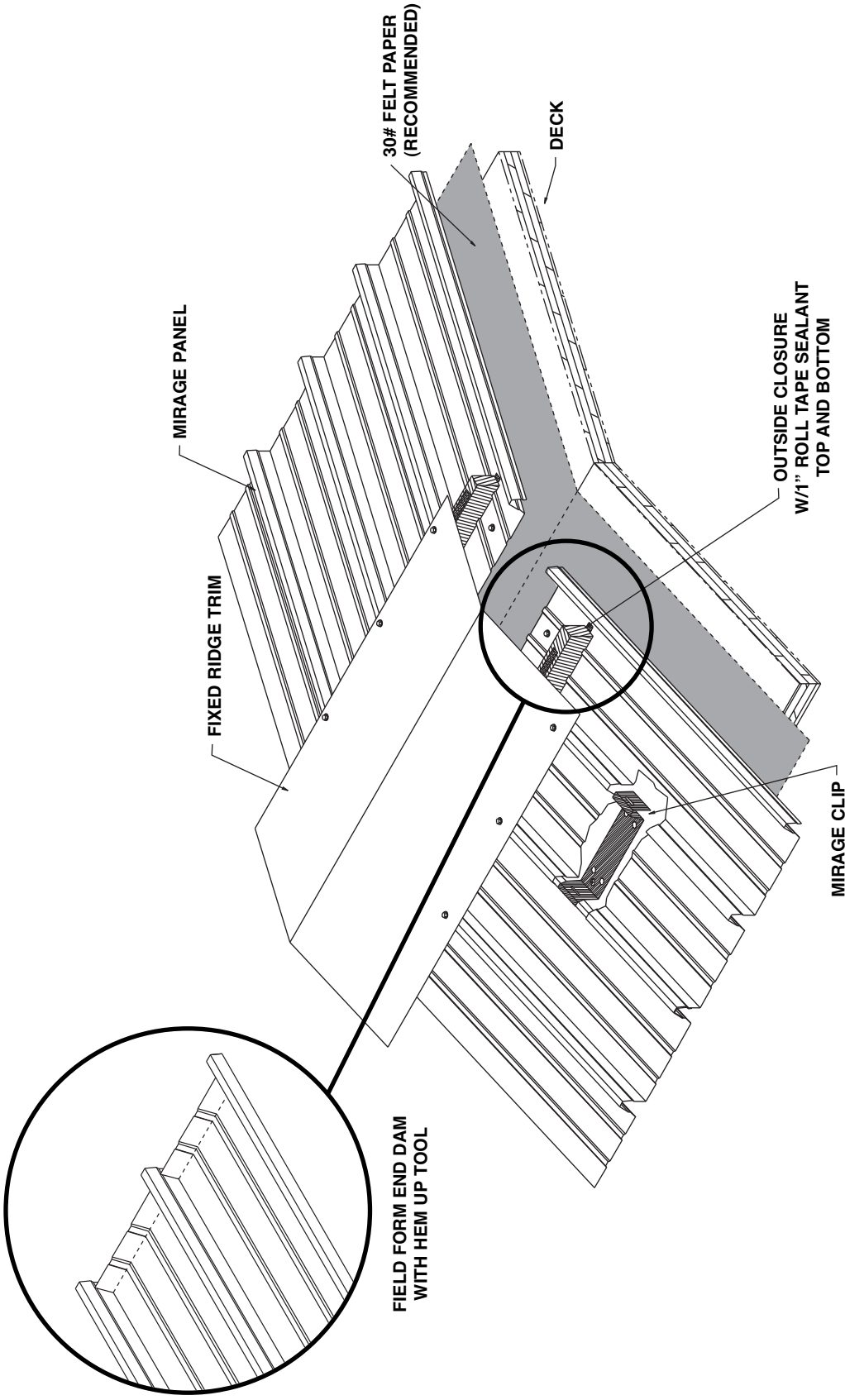

M c E l r o y M e t a l

**Mirage
FIXED RIDGE
W/DECK**

Technical Service: 1-800-950-9082

OUTSIDE CLOSURE

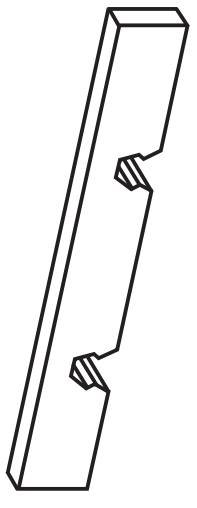

FIXED RIDGE TRIM

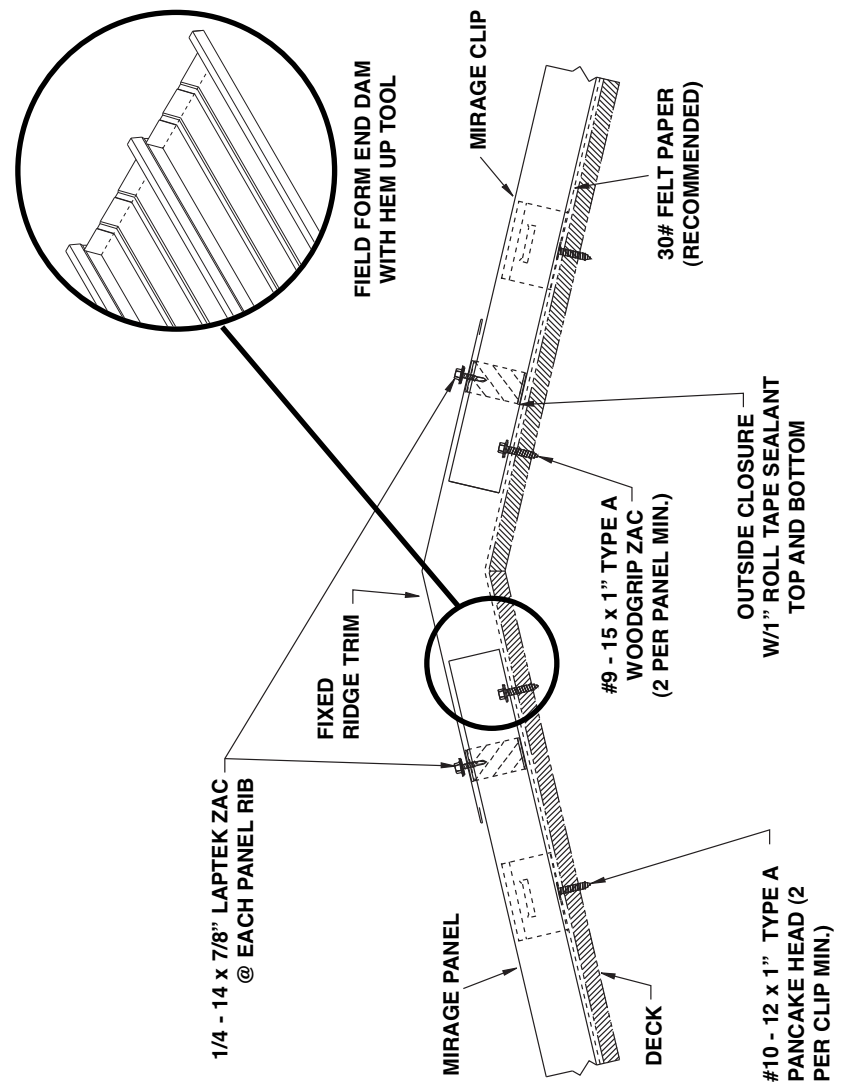
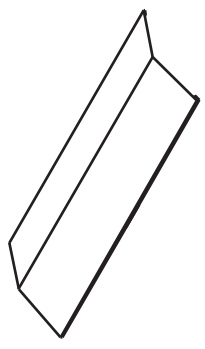

NOTES

1. Attach Mirage Panel to deck with #9 - 15 x 1" Type A Woodgrip ZAC - 2 per panel (min.).
2. Place Outside Closure with 1" Roll Tape Sealant on top and bottom of closure.
3. Attach Ridge Trim with 1/4 - 14 x 7/8" LAPTEK ZAC at each major rib. Fasteners must penetrate sealant.



M c E l r o y M e t a l
Mirage
FIXED RIDGE
W/DECK DETAIL

Technical Service: 1-800-950-9082



☆ MANUFACTURING LOCATIONS ● SERVICE CENTERS ★ MANUFACTURING AND SERVICE CENTER



CORPORATE OFFICE
1500 HAMILTON RD.
BOSSIER CITY, LA 71111

MANUFACTURING LOCATIONS

- | | | | |
|--------------|--------------------|------------------|----------------|
| ADELANTO, CA | ASHBURN, GA | BOSSIER CITY, LA | CLINTON, IL |
| HOUSTON, TX | LEWISPORT, KY | MARSHALL, MI | MAUSTON, WI |
| MERKEL, TX | PEACHTREE CITY, GA | SUNNYVALE, TX | WINCHESTER, VA |

MCELROY METAL
SERVICE
C E N T E R

- | | | | |
|--|--|--|--|
| 5215 Leo St.
Alexandria, LA 71301 | 1007 Wilso Dr,
Baltimore, MD 21223 | 1500 Hamilton Rd.
Bossier City, LA 71111 | 3052 Yadkin Road
Chesapeake, VA 23323 |
| 9476 Meadowbrook Rd.
Clinton, IL 61727 | 3215 Highway 59
Diamond, MO 64840 | 390 N. Valley Dell Dr.
Fenton, MO 63026 | 409 Lovejoy Road
Ft. Walton Beach, FL 32548 |
| 3014 Lincoln Court
Garland, TX 75041 | 1440 Aldine Bender Road
Houston, TX 77032 | 10504 E. 59th Street
Indianapolis, IN 46236 | 9435 US Hwy. 60 W.
Lewisport, KY 42351 |
| 5123 Terminal Dr.
McFarland, WI 53558 | 514 Cave Road
Nashville, TN 37210 | 8304 Hwy. 70 E.
North Little Rock, AR 72117 | 613 North Bierdeman Rd.
Pearl, MS 39208 |
| 7450 Tower Street
Richland Hills, TX 76118 | 5300 83rd Street
Sacramento, CA 95826 | 1365 Dean Forest Rd.
Savannah, GA 31405 | |
| 7355 Oakley Industrial Blvd.
Union City, GA 30291 | 1144 Silstar Rd.
West Columbia, SC 29170 | 325 McGhee Rd.
Winchester, VA 22603 | |

Website: www.mcelroymetal.com • E-mail: info@mcelroymetal.com